





# Identifying Inventions in the Public Domain

A Guide for Inventors and Entrepreneurs

Except where otherwise indicated, this publication is licensed under the Creative Commons Attribution 3.0 IGO License.

The user is allowed to reproduce, distribute, adapt, translate and publicly perform this publication, including for commercial purposes, without explicit permission, provided that the content is accompanied by an acknowledgment that WIPO is the source and that it is clearly indicated if changes were made to the original content.

Suggested citation: WIPO (2020), *Identifying Inventions in the Public Domain: A Guide for Inventors and Entrepreneurs*. Geneva: WIPO.

Adaptation/translation/derivatives should not carry any official emblem or logo, unless they have been approved and validated by WIPO. Please contact us via the WIPO website to obtain permission.

For any derivative work, please include the following disclaimer: "The Secretariat of WIPO assumes no liability or responsibility with regard to the transformation or translation of the original content."

When content published by WIPO, such as images, graphics, trademarks or logos, is attributed to a third party, the user of such content is solely responsible for clearing the rights with the right holder(s).

To view a copy of this license, please visit <https://creativecommons.org/licenses/by/3.0/igo>

The designations employed and the presentation of material throughout this publication do not imply the expression of any opinion whatsoever on the part of WIPO concerning the legal status of any country, territory or area or of its authorities, or concerning the delimitation of its frontiers or boundaries.

This publication is not intended to reflect the views of the Member States or the WIPO Secretariat. The mention of specific companies or products of manufacturers does not imply that they are endorsed or recommended by WIPO in preference to others of a similar nature that are not mentioned.

© WIPO, 2020

First published 2020

World Intellectual Property Organization  
34, chemin des Colombettes, P.O. Box 18  
CH-1211 Geneva 20, Switzerland

ISBN: 978-92-805-3039-1



Attribution 3.0 IGO  
(CC BY 3.0 IGO)

Photo credits: United States Patent 4,240,194;  
olga\_hmelevska/iStock/Getty Images Plus  
Printed in Switzerland

# Table of contents

<b>Acknowledgments</b>	<b>8</b>	<b>Module II</b>	
<b>Introduction to the guide</b>	<b>9</b>	<b>Identifying technology information needs</b>	<b>29</b>
<b>Module I</b>		<b>1. Introduction</b>	<b>29</b>
<b>Patents and the public domain</b>	<b>13</b>	<b>2. Information to be gathered from the client</b>	<b>30</b>
<b>1. Introduction</b>	<b>13</b>	2.1 Technical information	30
<b>2. Patent rights and the public domain for inventions</b>	<b>14</b>	2.2 Business information	34
2.1 Patent rights and scope of coverage	14	<b>3. Follow-on analysis and Summary Report</b>	<b>37</b>
2.2 Patent rights covering an invention	16	3.1 Summary Report Part A. Technical information	37
2.3 Public domain	19	3.2 Summary Report Part B. Business information	38
2.4 A workable approach to questions of public domain: Searching and analyzing published patent documents	22	3.3 Summary Report Part C. Additional analysis	38
<b>3. Freedom to operate (FTO) determination</b>	<b>24</b>	<b>4. Conclusion</b>	<b>40</b>
3.1 Principles and practices of FTO determination: Three stages	24	<b>Module III</b>	
3.2 A WHAT-WHERE-WHEN model for FTO determination	24	<b>FTO search: Finding sources of information to identify inventions in the public domain and carrying out an FTO search</b>	<b>41</b>
3.3 Possible outcomes of FTO determination	24	<b>1. Introduction</b>	<b>41</b>
3.4 Goals and uses of FTO determination	25	<b>2. Preparation for search: Deconstructing the invention</b>	<b>42</b>
3.5 FTO determinations may need to be updated or modified	25	2.1 FTO search to find potential dominant patents	42
<b>4. Uncertainty, potential error, risks and limitations of FTO determination</b>	<b>25</b>	2.2 Expanded list of keywords and phrases to use in search queries	44
<b>5. Other uses of FTO tools: Identify subject matter that is not covered by patent rights and may provide possible alternatives</b>	<b>26</b>	<b>3. Patent classification symbols associated with the invention</b>	<b>46</b>
<b>6. Conclusion</b>	<b>26</b>		

3.1 Use screening tools to find potentially relevant classification symbols: Mapping keywords to patent classification symbols	48	<b>6. The Search Report</b>	<b>62</b>
3.2 Find IPC symbols in patent documents you have identified before beginning the search	49	6.1 Format the search results	62
3.3 Find and refine IPC symbols through keyword searching	49	6.2 Search Report	63
3.4 Rank and test IPC symbols for relevance	49	<b>Module IV</b>	
3.5 Use cross-references and co-assignment data to find related IPC symbols and add these to your search	49	<b>FTO analysis: Reading claims and legal status information</b>	<b>65</b>
3.6 Optional: Use patent classification information to find additional potential keywords	49	<b>1. Introduction</b>	<b>65</b>
<b>4. Select database(s) to search</b>	<b>50</b>	<b>2. Organization of FTO analysis</b>	<b>66</b>
<b>5. Carrying out the FTO search: A hybrid strategy using keywords and patent classification symbols</b>	<b>51</b>	2.1 Choose the order in which you practice infringement analysis and legal status determination	66
5.1 Overview: Search claims and abstracts first	51	2.2 Decide whether to sort and prioritize search results	67
5.2 Tools for designing keyword search strings	51	<b>3. Background to FTO analysis: Claims in patent documents</b>	<b>67</b>
5.3 Develop a search string: Query creation	53	3.1 Claim structure	68
5.4 Carry out initial search and initial review	53	3.2 Types of claims: Classification by scope, function and/or subject matter	69
5.5 Modifications	54	<b>4. Infringement analysis: Claim construction and comparison of construed claims with the client's invention</b>	<b>72</b>
5.6 Searching "WHERE" and "WHEN" based on the client's plans for using the invention: Adding geographical limits and time frames to search	56	4.1 Claim construction	72
5.7 Searching non-text features using specialist databases or functions	58	4.2 Comparison of construed claims with the client's invention	77
5.8 FTO search as an iterative process: Review, refine, repeat... stop	62	4.3 Option: Carry out the comparison step before undertaking extensive claim construction	78
5.9 Collect the final set of search results to use for preparing the Search Report	62	4.4 Infringement analysis when claims include non-text features	81
		<b>5. Determining legal status</b>	<b>84</b>
		5.1 Patent term, expiration and abandonment	85
		5.2 Other factors to consider in determining legal status	86

5.3 Sources of information for determining legal status	87	6.1 If FTO search and analysis of patent documents in a country of interest did not result in classifying any patent as a “patent of interest – in force” in that country	97
<b>6. Making final determinations</b>	<b>88</b>	6.2 If FTO search and analysis of patent documents in a country of interest resulted in classifying at least one patent as a “patent of interest – in force” in that country	97
6.1 Classify each claim	88	<b>7. Conclusion</b>	<b>98</b>
6.2 Classify each patent	88	<b>Annexes</b>	<b>99</b>
<b>7. The Final Report</b>	<b>89</b>	<b>Endnotes</b>	<b>115</b>
7.1 Summary of the invention	90		
7.2 Summary of FTO search	90		
7.3 FTO analysis	90		
7.4 Option for additional analysis	91		
7.5 Conclusions	91		
7.6 Risks and limitations	92		

**Module V**  
**Understanding limitations and risks associated with FTO determinations: Risk management and how to use results** **93**

<b>1. Introduction</b>	<b>93</b>
<b>2. Uncertainty associated with the premise of FTO determination</b>	<b>94</b>
<b>3. Limitations and risks associated with identifying information needs (Module II)</b>	<b>94</b>
<b>4. Limitations and risks associated with FTO searching (Module III)</b>	<b>94</b>
4.1 Limitations of the search process	94
4.2 Limitations inherent in the data being searched or retrieved	95
<b>5. Limitations and risks associated with FTO analysis and the Final Report (Module IV)</b>	<b>96</b>
<b>6. Going forward: Using the results in the Final Report</b>	<b>97</b>

# Acknowledgments

This publication is a result of a project commissioned by the World Intellectual Property Organization (WIPO) Development Agenda Project on the Use of Information in the Public Domain for Economic Development. The lead subject matter expert was Donna O. Perdue, and the associate subject matter experts were Rose A. Mboya, Sarasija Padmanabhan and Isaac Rutenberg.



# Introduction to the guide

The purpose of this guide is to help you determine whether specific inventions appear to be protected by enforceable patents, or may be in the public domain. The guide teaches you the steps involved in making this determination, and provides training and tools for each step.

Because patent rights are national in scope and have a limited duration, the guide teaches you how to carry out these steps using a complete technical description of a specific invention in combination with information about the countries where the invention might be used and the time frame for use. The guide also educates you about limits and risks associated with each step.

## Basic concepts used in this guide

The guide defines inventions, patents and public domain as follows.

**Invention:** A product or process that provides a new approach to doing something, or offers a new technical solution to a problem. An invention has one or more features that contribute to producing a technical effect that provides the new approach or technical solution.



### Patented invention

A patent grants rights in a patented invention. These rights are:

- defined by the claims of the patent
- effective in the country that granted the patent
- enforceable for a limited time.

A patent grants the patent owner the right to stop or prevent others from practicing the patented invention without the patent owner's consent in the country that granted the patent, at any time when the patent is in force.

**An invention may be covered by multiple patents.** For example, a previous patent may cover a single feature of the invention, or multiple features of the invention. An invention may be covered by multiple patents, each of which covers a different feature or a collection of features found in the invention.



### Public domain invention

A public domain invention is:

- a publicly disclosed invention
- not covered by any enforceable patent rights in a specific country, at a defined time, such that anyone may freely use that invention in that country at that time, without liability for patent infringement.

**Because an invention may be covered by multiple patents,** determining whether an invention may be a public domain invention requires searching and analyzing published patent documents to determine whether there are *any* enforceable patents with claims that might cover the invention as a whole, or might cover *any* feature of the invention, in a specific country during a defined time frame.

Using this conceptual framework, the guide teaches you a three-stage process for searching and analyzing published patent documents using the tools of freedom to operate (FTO) determination.

**DESCRIBE**  
**(Module II)**

↓

**SEARCH**  
**(Module III)**

↓

**ANALYZE**  
**(Module IV)**

- Gather information from the client about the invention:
    - What is the invention and what does the client plan to do with it?
    - Where does the client plan to use the invention?
    - When does the client plan to use the invention?
  - Describe the invention and its planned use.
- 
- Break down the invention into parts and identify features to search.
  - Choose search parameters and resources: keywords; patent classification symbols; databases; countries; year(s); language(s).
  - Search for patent documents with claims that might cover the invention or one of its essential features, and identify potentially relevant documents to analyze.
- 
- Analyze each potentially relevant patent document:
    - Analyze claims to determine the scope of patent rights. Could a claim be interpreted in such a way that it might be found to cover the invention or one of its essential features? Yes/No/Cannot determine.
    - Determine the legal status of each analyzed patent. Is it still in force? If so, where is it enforceable and for how long? If not, is it expired, abandoned, invalidated, disclaimed or revoked? Is the legal status ambiguous or unsettled?

Possible outcomes of carrying out informal FTO analysis using the tools taught in the guide include:

- Enforceable patents are found with claims that could be interpreted in a way that they might be found to cover the invention or one of its essential features, in a specific country and during the time frame of planned use.
- No enforceable patents are found with claims that might be found to cover the invention or any of its features, in a specific country during the defined time frame.
- No final determination can be made.

**Using the guide: Skills, training, tools and strategies**

**Skills.** The guide assumes you already have a sound knowledge of intellectual property (IP), patent databases and patent information search skills, including:

- Basic working knowledge of IP and IP rights.
- Basic knowledge of patents and patent systems, including:
  - the process for filing and prosecuting patent applications to obtain one or more patents
  - the function and purpose of patent claims
  - basic knowledge of national and international patent systems.
- Basic knowledge of patent searching, including:
  - the use of keywords, patent classification systems, and search operators
  - the ability to evaluate and select patent databases based on search needs
  - the collection and organization of search results.

You can develop these skills using freely available resources, such as those available from the World Intellectual Property Organization (WIPO). Working through the process taught in this guide will enhance your existing skills and teach you new ones.

**Training.** Each module of the guide begins with a list of learning points that summarizes the knowledge and skills you should have acquired after completing the module. The guide provides detailed explanations of the principles and process of each step, and teaching examples that

illustrate how to carry out these steps. This training will provide you with useful professional skills to carry out your own projects using the tools of FTO determination. The guide also provides valuable training to help you understand the potential limitations, errors and risks associated with this process, and to take steps to manage these risks. The guide is a companion publication to the WIPO publication *Using Inventions in the Public Domain: A Guide for Inventors and Entrepreneurs (2020)* which looks at how to use information in the public domain and integrate it into the design and development of new products and services.

**Tools.** The practical tools in Annexes A, B and C are essential for using the guide effectively:

- Comprehensive checklists are provided for the “hands-on” modules – Module II (gathering information) at Annex A.1, Module III (FTO searching) at Annex B.1 and Module IV (FTO analysis) at Annex C.1.
- Templates for reports (Annexes A.2 and C.3) and claim charts (Annex C.2.a and C.2.b) provide structure and guidance for carrying out specific actions and generating work products for each stage of the process.
- You will also find a list of tools and additional resources that may be useful, such as WIPO publications, online tools and training materials (Annex D).

**Strategies.** You can choose how to approach the guide according to your own skills, needs and interests. Because of the large amount of detailed information presented in the guide, you may wish to use the helpful strategies highlighted here.

#### Strategy for becoming familiar with the guide

- Read Module I for principles, legal foundations and a comprehensive overview.
- Review Figure 1 to use as a **road map** of the process.
- Read the learning points for Modules II, III, IV and V to preview what you will learn from the guide.
- Review the checklists for Modules II, III and IV to see what tasks you will perform at each stage.
- Then read Modules II, III and IV for detailed explanations and training.
- Read Module V to understand potential risks and approaches to risk management.

#### Strategy for using the guide to carry out a project

- Use the tools to organize your actions, and consult the guide to understand how and why to carry out these actions.
- Print or create electronic copies of the checklists for Module II (Annex A.1), Module III (Annex B.1) and Module IV (Annex C.1).
- When you begin a stage of the FTO determination process, follow the checklist to keep track of the tasks to be completed.
- Consult the guide for detailed information about how to perform a specific task.
- Search keywords to find information about the task in different parts of the guide.
- Use the templates as guides for your work, keeping in mind that you may need to customize them for each project.

**Concluding remarks.** Learning and practicing the process taught in the guide should allow you to achieve multiple goals. You should be able to provide useful information to your clients as a result of using the tools of FTO determination for informal FTO analysis. You should be able to address common misconceptions about patent rights and public domain. You will also contribute to your own professional development by enhancing your patent search and analysis skills.



# Module I

## Patents and the public domain

### 1. Introduction

You can gather valuable information about inventions in the millions of published patent documents that are currently available, and those that will be published in the future. By searching and analyzing this information, you may be able to distinguish between inventions that are covered by patent rights granted to patent owners, and inventions that appear to be in the public domain and are therefore available for anyone to use without liability for patent infringement. Many sectors of the innovation community could benefit from facilitated access to public domain inventions that have been disclosed and can be freely used, either as originally disclosed or as the basis for further innovation through improvements and new features. This guide will teach you principles and tools to help you investigate patent rights covering an invention, and may help you to identify inventions in the public domain.

#### Learning points

Once you have completed this module, you should understand:

- How patent rights are created, interpreted and enforced.
- How patent rights create a public domain for inventions.
- How an invention may be covered by multiple patents, including patents for separate features of the invention.
- How the question of patent rights around an invention can be explored using the tools of freedom to operate (FTO) determination.
- Why it can be difficult to conclusively identify inventions in the public domain.

### Terminology hint

**Public domain** is defined in *Black's Law Dictionary* 513 (Pocket Edition 1996) as follows:

“2. The realm of publications, inventions, and processes that are not protected by copyright and patent; things in the public domain can be appropriated by anyone without liability for infringement.”

### Terminology hint

The term **patent documents** refers to published patents and published patent applications.

Published patents can include patents that are currently in force, or patents that are unenforceable because they are expired, abandoned, withdrawn, completely or partially disclaimed, invalidated, revoked or otherwise held unenforceable.

Published patent applications can include pending applications, abandoned applications, withdrawn applications or applications that have expired. They may include applications filed in national or regional patent offices, as well as published International Applications filed under the Patent Cooperation Treaty (PCT).

## 2. Patent rights and the public domain for inventions

An “invention” as defined by the World Intellectual Property Organization (WIPO) refers to “a product or a process that provides, in general, a new way of doing something, or offers a new technical solution to a problem.”

An invention is characterized by one or more features that contribute to producing a technical effect that provides the new way of doing things, or the new technical solution. An invention feature can be new, previously disclosed, part of general technical knowledge or a previously patented invention.

### 2.1 Patent rights and scope of coverage

A patent is an exclusive right granted for an invention. A patent gives the patent owner the right to exclude others from making, using, selling, offering for sale or importing the invention defined in the patent claims, without the patent owner's consent, in the country that granted the patent, during the term when the patent is in force.<sup>1</sup> A patent therefore gives the patent owner the right to control who may use or “practice” the patented invention in a country where the patent is in force, for as long as the patent is in force.

For these exclusive patent rights to be granted, the invention must be: described in a patent document that is submitted to a patent office and eventually made available to the public; defined in one or more patent claims; and meet the applicable legal requirements for patentability. Patent rights are limited in scope, location and duration:

- **Patents have limited scope defined by the claims.** The scope of patent rights is defined by the claims of a patent granted under the laws of the country of grant.
- **Patents have geographical limits.** Patent rights are enforceable only in the country where they were granted or validated (country of grant).
- **Patents have temporal limits.** Patents are granted with a fixed patent term. A patent can expire at the end of its full term and patent rights are automatically extinguished at that time. Under certain circumstances, a patent can become unenforceable before the end of its full term and patent rights are extinguished when the patent becomes unenforceable.

The patent owner's exclusive patent rights in an invention can impact another party's plans to use the same invention, because the patent owner can grant or deny permission to practice the patented invention, and can sue for patent infringement. Thus, a patent owner can enforce their patent by exercising their right to exclude others from **practicing** the patented invention.

#### What does “practicing the patented invention” mean?

A patent claim has one or more claim limitations (also known as claim elements), each of which recites a feature of the claimed invention.

“Practicing the patented invention” means taking actions that perform each and every limitation (element) of the claim.

When a question arises about whether the actions of others (any party other than the patent owner) practice the patented invention, a two-step analysis called “infringement analysis” is used to evaluate the actions in question:

- **Step 1.** The claims of the patent are interpreted (construed) to determine what the patented invention is, and what actions would practice the patented invention.
- **Step 2.** The interpreted claim is then compared with the actions in question (the actions of others) to determine whether these actions would result in practicing the patented invention.

The comparison step (Step 2) compares the actions in question with the actions that are required for each limitation of the claim to determine if any of the actions in question would perform that limitation; if they do, then the limitation is considered to be “satisfied” or “met” by the actions in question.

If the comparison step shows that each and every limitation of a patent claim is satisfied by the actions in question, then the claim is said to “cover” or “read on” these actions, such that performing them would be considered practicing the patented invention recited in that claim. A patent would cover (read on) these actions when at least one claim of the patent covers (reads on) these actions. If a patent is found to cover (read on) these actions (the invention), then the patent owner’s permission would be necessary to carry out these actions (the invention).

Infringement analysis can be performed for actions that previously occurred, actions that are currently taking place, or actions that are proposed to take place in the future.

For this guide, your client’s proposed plan of action is called “the client’s invention” and infringement analysis will be performed for the client’s invention. Infringement analysis is discussed in detail in Module IV.

**Invention is incremental: Practicing a new invention may include practicing a previously patented invention, and a patent for the previously patented invention may cover the new invention**

Most new inventions build on previous inventions by improving them, adding new features or combining them in new ways to arrive at a new product or process that is identified as the new invention. If the previous invention was patented, then the previously patented invention is a feature of the new invention, and practicing the new invention includes practicing the previously patented invention.

If the relevant claims of the patent for the previously patented invention are open-ended, such that practicing the patented invention requires practicing all of the recited claim limitations (elements), and may *also* include additional features that are not recited in the claims (see Module IV, section 3.1, “Claim structure”), then the patent for the previously patented invention may be found to cover (read on) the new invention.

**Terminology hint**

If the actions in question are defined as **an invention** and infringement analysis finds that a patent claim would cover (read on) these actions, then the claim would cover (read on) the invention. A patent would cover (read on) the invention when at least one claim of the patent covers (reads on) the invention.

The term **infringe** should, strictly speaking, be used to refer to anyone other than the patent owner practicing a patented invention without the patent owner’s permission. However, the term is often used broadly to refer to anyone other than the patent owner practicing a patented invention, without stating whether permission was obtained.

Thus, if a claim covers an invention, then practicing the invention (without the patent owner’s permission) would infringe the claim. If a patent covers an invention, then practicing the invention (without the patent owner’s permission) would infringe the patent.

### Terminology hint

A patent that covers one or more features of a later invention is often called a **dominant patent** for that invention.

The owner of *any* patent that covers the invention (e.g., any “dominant” patent) can exclude others from practicing the patented invention without the owner’s permission, in the country that granted the patent, for as long as the patent is in force. Thus, a patent that covers even one feature of a new invention can have an impact on the ability to freely use the entire new invention as planned. Someone wanting to practice the new invention would have to seek permission from the owner of any dominant patent.

You can read an illustration of this concept in Teaching Example 1, showing how a patent can cover (read on) a proposed new invention. In this example, the new invention uses a patented water filter and adds additional features. Practicing the new invention thus includes practicing the patented invention. In this example, the relevant claims for the patented water filter are “open-ended” claims that would be considered to cover (read on) the new invention.

### Multiple patents can cover an invention

A new invention may build on multiple previous inventions, including some that are patented. That is, a new invention may include multiple previously patented inventions as features of the new invention. Teaching Example 2 illustrates how multiple patents can cover an invention that includes previously patented inventions as features.

Each patent has its legal effect separately from any other patents that cover other features of the invention, or the invention as a whole. Thus, someone wanting to practice the new invention would have to seek permission from the owner of any dominant patent. As shown in Teaching Example 2, even though the inventor of the new invention obtained a patent for the new invention, that inventor may still need to seek permission from owners of dominant patents covering features of the new invention, as long as each patent is in force.

## 2.2 Patent rights covering an invention

It is therefore useful to think about a *collection* of patent rights covering an invention. Limits on scope, location and duration of patent rights create boundaries for the patent rights that cover a patented invention.

### Patent rights covering an invention can be different in different countries

It is common practice to seek patents in selected countries related to the planned use of the invention, with the result that patent rights covering the invention will exist in some countries and not in others. A “family” of related patents can result, where each patent family member may be known as a “counterpart patent” or “corresponding patent” relative to other members of the patent family.

The scope of these patent rights may be different in each country where a patent is granted, due to different rules for patentable subject matter, novelty, claim interpretation, and so on. The length of time these patent rights are in force may also differ from country to country. For example,



**Teaching Example 1: A patent with open-ended claims can cover a new invention that includes additional features not found in the patent claims**

An inventor took a commercially available patented water filter that removes bacteria, cysts and viruses from water, and connected it to a column filled with activated charcoal to remove certain organic chemicals. The new invention thus involves passing water through the patented water filter, then through the activated charcoal column and collecting the final output.

The patent for the water filter has a single open-ended independent claim reciting the structure and materials of the filter, and dependent claims to methods of purifying water samples using the filter. The open-ended independent claim recites “a water filtration system comprising” a filter that has the structure and materials recited in the claim. This open-ended claim would cover a water filtration system that has a filter with the structure and materials exactly as recited in the claim, and *also* has additional features (additional structures and steps) that are not recited in the claim.

**New invention: Water filtration system with activated charcoal column**

Commercial water filter <b>connected to</b> column filled with activated charcoal <b>with</b> collector for output	→	Existing patent for the commercial water filter has open-ended claim to “a water filtration system comprising” a filter with this structure and these materials
---	---	---

In this case, the existing patent for the commercial water filter can cover the new water filtration system that includes additional features not found in the original patented invention. Someone wanting to practice the *new* water filtration system will probably have to seek permission from the owner of the existing patent for the commercial water filter.

**Teaching Example 2: Multiple patents can cover an invention**

An inventor developed a new chemical product called Component Z. As shown below, to do this the inventor improved on previous inventions using two patented chemicals, Component X and Component Y, and a patented method of mixing them under precise conditions of heat and pressure, to make Component Z. Component Z is new and has properties that could not be predicted from the properties of Component X and Component Y.

In Country A, the inventor filed a patent application for “the Component Z invention” on 12/12/2010. Patent #4 was granted in Country A on 10/10/2012 with claims that cover Component Z and methods of making Component Z. Patent #4 expires on 12/12/2030.

In Country A, other parties own patents that cover Component X, Component Y and the method of mixing X and Y. Component X is covered by Patent #1 that expires on 10/10/2024, Component Y is covered by Patent #2 that expires on 11/11/2026, and the mixing method is covered by Patent #3 that expires on 12/12/2028. The inventor of the Component Z invention used each patented component, and practiced the patented method, exactly as described in the open-ended claims of each patent. Therefore, Patent #1, Patent #2 and Patent #3 cover features of the new Component Z invention in Country A. Patent #1, Patent #2 and Patent #3 can be considered “dominant” patents to the Component Z invention.

**Component Z invention**

Component X	→	Patent #1, expires 10/10/2024
<b>and</b>		
Component Y	→	Patent #2, expires 11/11/2026
<b>mix</b>		
under heat and pressure	→	Patent #3, expires 12/12/2028
<b>make</b>		
Component Z	→	Patent #4, expires 12/12/2030 Patent #4 covers Component Z and methods of making it (i.e., the Component Z invention)

Even though the inventor owns Patent #4 for the Component Z invention, the inventor may need to seek permission from the owners of Patent #1, Patent #2 and Patent #3 in order to practice the patented invention of Patent #4, as long as each previous patent is in force. (Note that these dominant patents can be called “blocking” patents with respect to Patent #4.)

**Teaching Example 3: Patent rights covering an invention can be different in different countries**

**Country A.** For the Component Z invention described above, the patent rights covering the invention in Country A are shown below: the inventor obtained Patent #4 for the new invention, and Patent #1, Patent #2 and Patent #3 are currently in force.

Component X → Patent #1, expires 10/10/2024  
**and**  
 Component Y → Patent #2, expires 11/11/2026  
**mix**  
 under heat and pressure → Patent #3, expires 12/12/2028  
**make**  
 Component Z → Patent #4, expires 12/12/2030  
 Patent #4 covers Component Z and methods of making it

**Country B.** Component Z will also be made and used in Country B, where different patent rights cover the invention. Component X was not patented in Country B. However, Component Y, the mixing method, and the Component Z invention were patented in Country B. The patent rights granted by the Country B counterparts of Patent #2, Patent #3 and Patent #4 cover the Component Z invention in Country B as shown below.

Component X  
**and**  
 Component Y → Country B counterpart of Patent #2, expires 11/11/2026  
**mix**  
 under heat and pressure → Country B counterpart of Patent #3, expires 12/12/2028  
**make**  
 Component Z → Country B counterpart of Patent #4, expires 12/12/2030

**Teaching Example 4: Patent rights covering an invention will change over time**

**Country A, in 2018.** For the Component Z invention described above, the patent rights covering the invention in Country A in 2018 are:

Component X → Patent #1, expires 10/10/2024  
**and**  
 Component Y → Patent #2, expires 11/11/2026  
**mix**  
 under heat and pressure → Patent #3, expires 12/12/2028  
**make**  
 Component Z → Patent #4, expires 12/12/2030.  
 Patent #4 covers Component Z and methods of making it

**Country A, in 2025.** Patent #1 on Component X expired on 10/10/2024. Therefore, in 2025 the invention is only covered by Patent #2, Patent #3 and Patent #4 in Country A.

Component X  
**and**  
 Component Y → Patent #2, expires 11/11/2026  
**mix**  
 under heat and pressure → Patent #3, expires 12/12/2028  
**make**  
 Component Z → Patent #4, expires 12/12/2030.  
 Patent #4 covers Component Z and methods of making it

The patent rights covering an invention in a country will continue to change with each expiration of a patent that covers the invention in that country, and will change sooner if any of the patents become unenforceable before the end of their full term.

events in one country may render the patent unenforceable before the end of the full patent term in that country, while a counterpart patent in another country may remain in force for the full patent term. Thus, the patent rights that cover an invention can differ from country to country, as shown in Teaching Example 3.

### Patent rights covering an invention will change over time

Patents are granted with a fixed patent term, and patent rights are automatically extinguished when a patent expires at the end of its full term (see Teaching Example 4). Under certain circumstances, a patent can become unenforceable before the end of its full term. This occurs if a patent is invalidated, revoked, abandoned (e.g., because renewal fees were not paid), withdrawn, disclaimed, allowed to lapse, dedicated to the public, or declared unenforceable for any other reason. The owner's exclusive rights in the invention recited in the claims are extinguished when the patent becomes unenforceable.

## 2.3 Public domain

There is no single official definition of the public domain for purposes of patent law, but it is important to recognize that the question of public domain relates to practicing an invention. Patent documents disclose information that can be freely used by the public, including technical details of the patented invention, details of other inventions not covered by patent claims, general technical knowledge and strategic information about prior attempts to address the same or a similar problem. In the claims, patent documents define the exclusive rights granted to the patent owner and provide the public with notice of what actions require the patent owner's permission.

In view of these different types of public disclosures, some commentators have proposed a "patent public domain" model with two dimensions: an information domain and an action domain.<sup>2</sup> This guide considers the question of public domain by teaching you how to evaluate patent rights for their potential to have an impact on your client's plans to use their invention.

### A workable approach to understanding public domain

A workable approach to understanding the public domain must focus on a specific invention and apply two key concepts:

- Patents have limited scope, location and duration.
- Multiple patents may cover the invention.

Limits on scope, location and duration of patent rights create boundaries for patent rights. These boundaries also define a public domain that is not covered by patent rights. Because multiple patents can cover one invention, an invention may have a collection of different patent rights associated with it. Limits on scope, location and duration of patent rights mean that a different collection of patent rights may cover an invention in any country, at any point in time.

### Definition of public domain invention

Thinking of rights this way, an invention is in the public domain in a specific country at a defined time if it is publicly disclosed and *no* enforceable patents cover the invention in that country at that time. An individual or organization may freely use a public domain invention because they cannot rightfully be excluded from using it. In other words, no patent rights exist that would allow a patent owner to exclude or prevent others from using that invention in that country at that time. The individual or organization has no liability for patent infringement because there are no enforceable patents that cover the public domain invention.

Thus, any discussion of public domain must be defined in terms of a specific invention, in a specific country, at a specific time. The terms "**public domain invention**" or "**invention in the public domain**" should be understood to refer to a **publicly disclosed invention that is not covered by any enforceable patents in a specific country at a defined time**, such that any individual or organization may use the invention in that country at that time, without liability for patent infringement.

### How can an invention be in the public domain?

A publicly disclosed invention may have always been in the public domain in a country because it was never covered by patent rights in that country, or it may pass into the public domain because any patents that previously covered the invention are no longer in force. A publicly disclosed invention may have never been covered by patent rights in a country for various reasons, such as:

- It involves subject matter that was already known to the public.
- It could not be patented in that country, for example if it is directed to unpatentable subject matter.
- An application to patent the invention was rejected because it was made available to the public before a patent application was filed, or failed to meet other requirements for patentability.
- It fell within the "disclosure-dedication rule" (if it exists in that country) which provides that subject matter that

was disclosed in a patent specification, but not claimed in any granted patent, is dedicated to the public.

A previously patented invention may pass into the public domain when all patents that cover the invention have expired or become unenforceable. If a patent for an invention becomes unenforceable before the end of its full term, then the patent rights granted to the patent owner by that patent are extinguished before the end of the full patent term. However, the invention passes into the public domain *only* if *no* patents are still in force that cover *any* feature of the invention.

Inventions that are kept secret, for example as trade secrets, are not public domain inventions even though no patent rights cover them.

#### **An invention can be in the public domain in one country and not in another country**

Because patent rights are country-specific, the collection of patent rights that covers an invention will be different in each country. The collection of patent rights covering an invention will also change over time. Furthermore, an invention can be in the public domain in one country and not in another country, as illustrated in Teaching Example 5. At a defined time in a first country, there may be a patent for the invention as a whole, and multiple dominant patents that cover various features of the invention, and all of these patents are in force in the first country at that defined time. At the same time in a second country, an invention may be in the public domain because all patents covering the invention are no longer enforceable, with the result that there are *no* enforceable patent rights covering any feature of the invention in the second country at that time.

#### **Dedication to the public does not mean an invention is free to use**

A patent owner can dedicate a patent to the public by disclaiming the remainder of the patent term of an unexpired enforceable patent, and making a statement that the disclaimed subject matter is dedicated to the public. The patent owner has given up their enforcement rights against anyone who wishes to use the invention defined in the claims of that patent.

In some countries, such as the United States of America, there are formal mechanisms for disclaiming some or all of the claims of a patent. In other countries, there is no official mechanism but a public statement can be made that is then associated with the official patent file.

It is important to understand that disclaimer and dedication to the public *does not* necessarily mean an invention is in the public domain and is free to use, because other patents that cover features of the invention (dominant patents) may still be in force. If features of the invention are still covered by dominant patents, the invention that was “dedicated to the public” is not free to use for as long as any dominant patent is in force. That is, disclaimer or dedication to the public by one patent owner does not affect the ongoing patent rights of other patent owners. Teaching Example 6 provides more detail.

#### **Listing in a “public domain database” does not mean an invention is free to use**

Some countries, such as Chile and Mexico, have developed catalogs or searchable databases of “patents in the public domain” that include patents that have become unenforceable before the end of their full patent term for non-payment of renewal fees, invalidation, withdrawal or other reasons. If a patent listed on such a database has expired, or has become unenforceable before the end of its full patent term, then the patent rights granted by that patent are no longer in force. However, the invention is not necessarily in the public domain, because dominant patents that cover features of the invention may still be in force.

#### **Lack of a counterpart patent in a country does not mean an invention is free to use in that country**

An invention may be patented in selected countries where the patent owner plans to use the invention. As a result, patent rights covering the invention may exist in some countries and not in others. To search for a “family” of counterpart patents around the world, you can use information based on patent markings on a patented product or machine, or patents listed on associated packaging or inserts, or in a report about a useful invention. You may find that no counterpart patents exist in certain countries where you would like to use the invention. However, the invention is not necessarily in the public domain in those countries, because other patents that cover features of the invention may still be in force.

#### **Permission from one patent owner does not mean an invention is free to use**

A patent owner can grant permission to use the patented invention, usually in the form of a license that spells out terms and conditions for using the patented invention. By granting a license, the patent owner (the “licensor”) has given up their enforcement rights against the person given permission to use it (the

**Teaching Example 5: An invention can be in the public domain in one country and not in another country, at the same point in time**

In this illustration, an innovator wants to practice the Component Z invention – that is, make and sell Component Z – in Country A and Country C, starting in 2020. As shown below, in 2020 there are patents in force that would still cover the Component Z invention in Country A.

**Country A, in 2020.** For the Component Z invention described above, the patent rights covering the invention in Country A in 2020 are:

- Component X → Patent #1, expires 10/10/2024
- and**
- Component Y → Patent #2, expires 11/11/2026
- mix**
- under heat and pressure → Patent #3, expires 12/12/2028
- make**
- Component Z → Patent #4, expires 12/12/2030  
Patent #4 covers Component Z and methods of making it

**Country C, in 2020.** In country C, Component X, Component Y and the “heat and pressure” method were *never* patented. A counterpart patent of Patent #4 for the Component Z invention was granted in Country C, but then it was abandoned in 2015 because the renewal fees were not paid. Therefore, the patent rights covering the invention in Country C in 2020 are:

- Component X
- and**
- Component Y
- mix**
- under heat and pressure → ~~Country C counterpart of Patent #4~~  
Abandoned = no longer in force
- make**
- Component Z

The Component Z invention appears to have entered the public domain in Country C in 2015, when the only patent covering this invention became unenforceable. Therefore, in Country C in 2020, the Component Z invention appears to be in the public domain.

**Teaching Example 6: Dedication to the public does not mean an invention is free to use**

**Country D.** A patent portfolio was developed based on Patent #4 covering the Component Z invention, including a counterpart patent in Country D. The patent owner dedicated the Country D counterpart of Patent #4 to the public in 2016, in response to a local crisis. As a result, the patent rights of the Country D counterpart of Patent #4 became unenforceable in 2016.

Component Y, an inexpensive chemical that is used for many different purposes, is patented in Country D. The Country D counterpart of Patent #2 is still in force, expiring on 11/11/2026. Component X and the method of mixing were never patented in Country D.

**In 2018,** the patent rights covering the invention in Country D are:

- Component X
- and**
- Component Y → Country D counterpart of Patent #2, expires 11/11/2026
- mix**
- under heat and pressure
- make**
- Component Z → ~~Country D counterpart of Patent #4, expires 12/12/2030~~  
**Patent dedicated to the public in 2016 is no longer in force**

As this illustration shows, even though the patent for the Component Z invention was dedicated to the public in 2016, a dominant patent that covers one of the invention features is still in force. Therefore, the Component Z invention is not necessarily free to use in Country D in 2018.

“licensee”), as long as the terms of the license are followed. If there are additional dominant patents that cover the licensed invention, including patents that are dominant patents to the licensed patent, then it may still be necessary to also get the permission of the owners of the dominant patents. These issues are routinely addressed in licensing negotiations and will not be discussed further in this guide.

### **Other IP rights may impact the ability to use the invention**

Other IP rights may be associated with an invention, such as trademark rights, industrial design rights or copyright, and these rights may still be in force after patents that cover the invention expire or become unenforceable. Although these IP rights do not cover the same subject matter as patents, they may nonetheless impact the ability to freely use the invention. This guide *does not* consider non-patent IP rights, but you should be aware that other IP rights may be associated with an invention, and these IP rights may differ from country to country, and time to time. Thus, it may be necessary to seek permission from the owners of non-patent IP rights in order to practice an invention as planned.

### **The importance of the public domain**

The importance of the public domain is widely recognized by patent offices, boards of appeal, courts and other decision-making bodies that try to ensure that the public can know and rely on what is in the public domain. Most patent systems require a clear and complete public disclosure of information sufficient to allow a patent office to:

- determine what an inventor has invented
- decide whether any invention being claimed meets the statutory requirements for patenting
- define the legal boundaries of any exclusive patent rights granted in the claims of a patent
- protect the public’s right to know and be able to rely on what is in the public domain.

Despite the lack of patent laws and regulations directly addressing questions of public domain, patent offices and courts of many countries have produced useful guidance on protecting the public domain, most importantly by requiring public notice, complete disclosure and precise claims. For example, patent laws in the United States of America require that each patent claim must:

“[P]recisely inform persons skilled in the art of the boundaries of protected subject matter” so that “[t]he claim places the public on notice of the scope of the patentee’s right to exclude” and “the public

is informed of the boundaries of what constitutes infringement of the patent.”<sup>3</sup>

The public domain is also protected by public use and on-sale bars that serve to “discourage ‘the removal of inventions from the public domain which the public justifiably comes to believe are freely available.’”<sup>4</sup> The United States Patent and Trademark Office (USPTO) teaches that granting a patent on the discovery of an unknown or inherent property of a prior publicly available invention “would remove from the public that which is in the public domain by virtue of its inclusion in, or obviousness from, the prior art.”<sup>5</sup> Another patent doctrine that protects the public interest in the public domain is the “recapture rule” that prohibits patent reissue to “recapture” previously claimed subject matter that was surrendered in an application to obtain the original patent.<sup>6</sup> The disclosure-dedication rule is another doctrine that protects the public’s right to know what subject matter disclosed in a patent is protected by patent rights, and what subject matter is dedicated to the public.

## **2.4 A workable approach to questions of public domain: Searching and analyzing published patent documents**

A person who wants to use an invention also wants to know whether there are any existing (and enforceable) patent rights that would cover their planned use of the invention. In many cases, they want to know whether an invention is “in the public domain.”

As discussed above, the public domain for an invention is different in each country at each point in time, and the question of patent rights and public domain must be addressed for each country where they plan to use the invention, during the time frame when they plan to use the invention there (e.g., when they plan to start using a process or selling a product in that country). You can address this question by searching the disclosures in published patent documents and then analyzing potentially relevant documents to consider patent rights and public domain with respect to that invention.

### **The structure and contents of patent documents facilitate searching**

The structure and contents of patent documents will facilitate this approach. Patent documents provide information that is useful in two distinct ways:

- as legal information that can be used for searching and analyzing patent rights around an invention

- as technical and strategic information about inventions that can be freely used by anyone to enhance their technical understanding and make decisions about, for example, research, development, patenting or business planning.<sup>7</sup>

Patent documents have a standardized structure that allows searching with different inputs. Electronic files of published patent documents often make the entire patent record available as a searchable source of information. It is important to be aware that any IP rights that cover creative works detailed in patent documents must still be respected. For example, copyright may be created in drawings, charts, computer code or in some or all of the text of the specification, by virtue of being original creative works fixed in a tangible medium.

Patent documents often cite other literature that may be relevant, and may include links that enable access to additional information. Classification systems provide ways to find related patents that may use different words to describe similar technical features. Finally, because the patented invention is defined in the claims, patent documents provide information that could be used to identify subject matter that is *outside* the scope of the claims and may be in the public domain, such as additional inventions or alternatives that were disclosed in the specification but not claimed, or subject matter that was specifically disclaimed.

#### **The option to search in patents that expired at the end of their full term**

Inventions in the public domain could be easily identified by looking for inventions that were disclosed in patent documents that were filed and published so long ago that any patent rights in any country can reliably be assumed to have expired at the end of a full patent term, along with any dominant patents that ever covered features of the invention.

This approach may not be desirable for utility patents with a patent term of 20 years from the filing date (or more if any extensions were granted) because it would only identify inventions that use technology that was disclosed at least 20 years ago. This approach would require practicing an invention exactly as described and claimed in a patent that is more than 20 years old. Because most *current* inventions involve *current* technology, it is essential to explore patent rights involving current technology.

This approach may work differently for other instruments such as utility models, petty patents, innovation

models or mini-patents, all of which have shorter patent terms of between 5 and 15 years. Depending on the circumstances, it may be useful to search databases for other instruments such as utility models or petty patents that expired at the end of their full term, but still represent useful technology.

#### **Recap**

**An “invention” is a product or process that provides a new way of doing something, or offers a technical solution to a problem; it may use new or existing products, processes and knowledge, and may include new combinations of existing products or processes.**

**A patent is an exclusive right granted for an invention.**

#### **Patent rights are limited in:**

- **scope: claims within a patent define the scope of patent rights**
- **location: rights are enforceable only in the country where they were granted or validated**
- **duration: patents are granted for a fixed period of time.**

**A patent owner can enforce their patent, which means they have the right to exclude others from practicing the patented invention.**

**Infringement analysis is used to investigate whether actions by others (not the patent owner) would practice a patented invention.**

**A new invention may build on multiple previous inventions, including previously patented inventions; therefore, multiple patents may cover an invention.**

**An existing patent that covers even one feature of a new invention can have an impact on the ability to freely use the entire new invention as planned.**

**Patent rights are commonly sought only in the countries in which the invention is intended to be used; therefore, patent rights will exist in some countries but not in others.**

**A public domain invention is one that is not covered by any enforceable patent rights in a specific country at a defined time; an invention can be in the public domain in one country but not in another, so the question of patent rights and the public domain must be addressed separately for each country in which the invention may be used.**

### 3. Freedom to operate (FTO) determination

This guide teaches you how to explore patent rights around an invention by using an approach based on the principles and practices of freedom to operate (FTO) determination. FTO determination involves a multistep process to investigate whether a specific action can be performed in a way that does not appear to infringe any enforceable patents that are owned by others. FTO determinations are undertaken when someone wants to practice a well-defined invention in one or more countries beginning at a specific time, and they want to find out whether they have freedom to practice the invention as they have planned. That is, they want to know whether there are any enforceable patents with claims that could cover their planned use of the invention, in any of the intended countries, during the intended time period.

#### 3.1 Principles and practices of FTO determination: Three stages

FTO determination requires a working knowledge of how patent rights are created, interpreted and enforced, so that you can carry out a search and analysis of patent literature to determine whether there are any enforceable patents that appear to cover the planned use of an invention, and if so, where and when those patents are likely to be in force.

FTO determination is practiced in three stages:

1. Gathering information about the invention to be searched and plans for using it (identifying information needs).
2. Searching the published patent literature to find potentially relevant patent documents (FTO search).
3. Analyzing the claim scope and legal status of patents identified in the FTO search (FTO analysis) to evaluate what patent rights exist that might impact the freedom to use the invention as planned.

#### 3.2 A WHAT-WHERE-WHEN model for FTO determination

This guide teaches a “WHAT-WHERE-WHEN” model for FTO determination, based on the fact that patents have limited scope defined by their claims, geographical limits and temporal limits. As shown in Figure 1, the WHAT-WHERE-WHEN model is used at each

stage of FTO determination to identify and organize information.

You will start from a scenario in which a client discloses a new invention: a process or a product that the client has identified as an invention, characterized by a combination of technical features. The client also discloses their plans for using the invention in one or more countries during a specific time frame. For example, the client has developed a new way of diagnosing a medical condition, and a kit for performing the diagnosis, and wants to manufacture and sell diagnostic kits in China, India, Kenya and Mexico beginning in 2020.

The first stage is to gather information about the invention and the client’s planned use of the invention, and organize it into a format that enables you to define WHAT the client’s invention is, WHERE the client plans to use the invention (and how), and WHEN the client plans to use the invention.

The next stage is to deconstruct the invention into its parts and essential features, to develop generic descriptions of WHAT each feature of the invention is. You identify WHERE you need to search, and the time frame that covers WHEN the client plans to use the invention in each country. You develop search inputs (keywords and patent classification symbols), choose patent databases, develop search strategies, search patent databases and review any potentially relevant patent documents identified by the search.

In the third stage you interpret or “construe” each patent claim to determine WHAT the patented invention is. You then compare the construed claim with the client’s invention, and try to determine whether the claim would cover the client’s invention. You also try to determine the legal status of any patent of interest, to determine whether the patent owner has enforceable patent rights that could have an impact on WHAT the client plans to do with the invention in any country WHERE the client plans to use the invention, during any time WHEN the client plans to use it.

#### 3.3 Possible outcomes of FTO determination

An FTO determination may result in various outcomes depending on the invention being considered and the client’s plans for using it.

One outcome is that the FTO determination finds one or more enforceable patents with claims that could



be interpreted to cover (read on) the client's planned use of the invention in a country. The client may need to consider options such as seeking the permission of the patent owner(s) through licensing, technology sharing (joint ventures), or changing their plans. Further interpretation and FTO determination may need to be carried out by a qualified legal professional or patent professional of any country or countries where these patents were granted.

Another outcome is that the FTO determination does *not* find any patents that appear to be an obstacle to the client's planned use of the invention in a country. For example, the FTO search does not find any potentially relevant patent documents, or the FTO search finds potentially relevant patent documents but the FTO analysis shows that none of the claims appear to cover the client's invention. In another scenario, the FTO search finds potentially relevant patent documents and the FTO analysis identifies patent claims that appear to cover the client's planned use of the invention, but legal status determination shows that these claims are found in patents that are no longer in force because they expired or became unenforceable. None of these examples guarantees that the client's invention is in the public domain or otherwise free to use. However, the client may decide to interpret this outcome favorably, and proceed with their plans for using the invention.

In some cases, no conclusive FTO determination can be made because of factors such as uncertain claim scope, uncertain or unknown factors related to the client's invention, or unsettled legal status of the patent documents.

### 3.4 Goals and uses of FTO determination

As the term "freedom" suggests, one goal of an FTO determination is to look for circumstances where the invention can be practiced outside the scope of any patent rights owned by others. This goal will not necessarily be achieved, since FTO determination may find patents that raise potential FTO issues.

Thus, the main goal of an FTO determination is to provide notice of any existing or potential future patent rights that might be relevant to the planned use of the invention. With notice of potential FTO issues, your client can make choices about how to proceed. They can consider whether to seek a license from any patent owners. They can consider whether to make changes in the invention or in the way they will use it, for example by redesigning an invention feature, dropping one

or more countries from their business plan, or delaying launch in one or more countries until certain patents have expired. They can seek legal advice to determine whether any exemptions or exceptions apply to their circumstances. If a patent appears to be a potential obstacle to practicing their invention as planned, they may decide to challenge the patent, in an attempt to remove the patent by having it invalidated or otherwise found unenforceable.

### 3.5 FTO determinations may need to be updated or modified

An FTO determination could become obsolete, irrelevant or moot. Because an FTO determination relies on current information to make a prediction about the future outcome of a hypothetical litigation that could ensue *if* an accusation of infringement were to be made, the unpredictable nature of future events could render a current FTO determination obsolete, or lead to a different outcome. FTO determinations may therefore need to be updated to find documents that were not published when an earlier determination was carried out.

## 4. Uncertainty, potential error, risks and limitations of FTO determination

In an ideal system, a completely accurate definition of the invention would be used in a perfectly comprehensive search and analysis process that would reliably identify any and all patents that cover the planned use of the invention. In such an ideal system, not finding any patent rights that cover the planned use of the invention would be taken as a finding that the invention is in the public domain, for the purpose of using the invention as planned, in a specific country, during a specific time frame.

In actual practice, FTO determination is associated with uncertainty and potential error at each stage (see Module V), such that it can be difficult to confidently conclude that an invention using current technology is in the public domain or otherwise free to use.

Uncertainty or technical error can arise from how the invention is characterized, how the technical disclosure in patent documents is characterized and how information was entered into and retrieved from databases. The accuracy of the FTO search is sensitive to factors such as the quality and content of the databases searched, the timeliness of database contents, the accuracy of search inputs, the scope

of the search and the quality of support tools such as translation or expansion functions. There is also uncertainty or error associated with infringement analysis, due to the ongoing evolution of rules and standards throughout the world. The legal status of a patent document may be uncertain or unsettled. Although the tools taught in this guide can be extremely useful, it is important to recognize both their strengths and their limitations.

FTO determination is limited to trying to identify and analyze patent documents in order to explore the patents (or lack thereof) covering an invention. FTO determination *does not* address questions such as whether an invention could be used without obtaining permission from the owner of a dominant patent because an exception or an exemption might apply to a specific set of facts under the laws or legal doctrines of a specific country. For example, some countries may allow a “research exemption” (sometimes called a research exception, experimental use exception or exemption for medical use) in defined circumstances. In some countries, certain actions may fall under a “patent exhaustion” doctrine (sometimes called a first sale doctrine) that permits a purchaser to make further use of the patented invention without the patent owner’s permission, even though the patent is still in force. A legal professional must be consulted for questions related to possible exceptions or exemptions, or whether patent exhaustion would apply.

This guide is only concerned with FTO determination related to patent rights. As noted elsewhere, other IP rights may be associated with the client’s invention, such as trademark rights, industrial design rights or copyright, and these rights may still be in force after patents that cover the invention have expired or become unenforceable. Other constraints that could affect how the invention can be used include regulatory controls, import/export controls, restrictions on the use of genetic resources or traditional knowledge and “tangible property” (TP) restrictions that may be found in material transfer agreements, supply contracts (especially for essential components), labor contracts or collaboration agreements. Thus, even if an FTO determination does not identify any obstacles related to patent rights owned by others, there may be other constraints on the client’s freedom to use the invention as they planned.

#### **Recognizing limitations and minimizing risk**

This guide teaches you how to use the tools of FTO determination to search and analyze the patent literature. It teaches you how to apply general principles of infringement analysis to patent documents from multiple

jurisdictions, and general rules for determining the legal status of a patent document regardless of jurisdiction, to enable you to carry out an informal FTO analysis. The result of using these tools is a technical Final Report that *does not* constitute a legal opinion, legal advice or business advice. Because FTO determinations are often carried out by legal professionals who *can* give a legal opinion concerning whether or not a patent appears to cover the invention, it is very important to minimize risk by distinguishing the informal FTO analysis you will carry out. You must inform the client that any results or reports generated using the tools of FTO determination as taught in this guide *do not* substitute for the advice of a legal professional. A detailed description of risks, limitations and actions for risk management for FTO determination is found in Module V.

### **5. Other uses of FTO tools: Identify subject matter that is not covered by patent rights and may provide possible alternatives**

When you use the tools of FTO determination to actively explore patent rights around an invention, you may find subject matter that is not covered by patent rights and could represent alternative ways of solving a problem related to the client’s invention. For example, a patent document may disclose multiple distinct inventions, but only one of the disclosed inventions was patented.

If you find potential problem patents, your client may want to consider alternative ways of solving the problems being addressed by their invention, so that those patents would no longer cover the new invention. You may be able to supply information about alternatives that were disclosed but not claimed and may fall within the “disclosure-dedication rule” mentioned earlier.

If your client wants to consider changes to their invention, it will be important to decide whether a new FTO determination is necessary. The original FTO determination is designed to search for patents with claims that might cover (read on) the client’s invention as originally defined. If the client wants to modify the invention to use alternatives, then the modified invention may be different from the invention of the original FTO search. A new FTO determination for the modified invention may be necessary.

### **6. Conclusion**

Using the approach taught in this guide will require you to use skills you already have and to learn new skills

Figure 1: FTO determination using the WHAT-WHERE-WHEN model

Objective	Sample interview questions
<p><b>Identify information needs and describe the invention</b></p> <p>↓</p>	<ul style="list-style-type: none"> <li>- Interview client to learn:               <ul style="list-style-type: none"> <li>· <b>WHAT</b> the invention is and <b>WHAT</b> the client plans to do with it.</li> <li>· <b>WHERE</b> the client plans to use the invention.</li> <li>· <b>WHEN</b> the client plans to use the invention.</li> </ul> </li> <li>- Prepare Summary Report describing the invention and the client's plans for using it, with information in a suitable format to use for FTO search.</li> </ul>
<p><b>FTO search</b></p> <p>↓</p>	<ul style="list-style-type: none"> <li>- Use Summary Report to develop inputs for FTO search:               <ul style="list-style-type: none"> <li>· <b>WHAT.</b> Define features with keywords; patent classification symbols (International Patent Classification (IPC) symbols) for invention; identify non-text features.</li> <li>· <b>WHERE.</b> Identify countries to be searched, languages required.</li> <li>· <b>WHEN.</b> Define time frames for search, if any.</li> </ul> </li> <li>- <b>Find databases and tools</b> that will support the search.</li> <li>- <b>Develop search strategies.</b> For example search strings using keywords in combination with IPC symbols.</li> <li>- <b>Carry out FTO searches.</b> Review, refine, repeat as necessary.</li> <li>- <b>Identify potentially relevant patent documents</b> for further analysis.</li> <li>- <b>Prepare FTO Search Report</b> with search summary and search results.</li> </ul>
<p><b>FTO analysis</b></p>	<ul style="list-style-type: none"> <li>- Carry out informal <b>FTO analysis</b> for each potentially relevant patent document identified in the FTO search:               <ul style="list-style-type: none"> <li>· <b>Infringement analysis.</b> Construe (interpret) the scope of claims and compare the client's invention with each construed claim. Do any claims appear to cover (read on) the client's invention?</li> <li>· <b>Legal status determination.</b> Are there enforceable patent rights or potential future rights? If yes, in what country and during what time frame?</li> </ul> </li> <li>- <b>Prepare Final Report.</b> Did FTO analysis identify any enforceable patents that could have an impact on <b>WHAT</b> the client plans to do with the invention, in any country <b>WHERE</b> the client plans to use the invention, during the time <b>WHEN</b> the client plans to use the invention?</li> <li>- <b>Final Report should state technical findings and analysis</b>, and should <i>not</i> use legal language.</li> <li>- Final Report should <b>discuss risks</b> associated with FTO determination.</li> </ul>

as well. This approach requires patent-searching skills for finding relevant patent documents, technical skills for interpreting patent documents and analytical skills for synthesizing your findings to conclude whether or not you have found any claims that might cover the client's planned use of the invention. You will learn how to use FTO principles and tools as taught in this guide to support the goal of identifying inventions in the public domain. You will also learn the limitations and uncertainties associated with the FTO approach, in order to understand why the accuracy of your search, analysis and conclusions cannot be guaranteed, why it may be difficult to determine the status of an invention with respect to the public domain and why there is no guarantee that inventions in the public domain can be conclusively identified.

By using FTO principles and tools to investigate patent rights around an invention, you can provide a client with information that will help them make informed decisions about their plans to use an invention. Using the tools taught here may help to identify inventions in the public domain, as well as to manage risks from the uncertainties associated with trying to identify inventions in the public domain.

## Recap

**FTO determination is a multistep process that investigates whether a proposed invention can be practiced without infringing any enforceable patents owned by others.**

**A 'WHAT-WHERE-WHEN' model is an approach to FTO determination that can be used at each stage of the process to identify and organize information.**

**Potentially relevant patent documents identified by an FTO search should be analyzed to assess whether any of the claims might be interpreted to cover (read on) the proposed invention, and to determine whether the document grants any enforceable patent rights in a country where, and at a time when, the client plans to use their invention.**

**FTO determinations may need updating as new patent documents are published and new patents come into force; a new FTO determination may be needed if modifications are made to a proposed invention.**

**The uncertainties and potential errors associated with FTO determination mean that it can be difficult to conclude with confidence that an invention using current technology is free to use, in particular to conclude that an invention is in the public domain.**

**There may be other constraints on freedom to use an invention as planned, such as other IP rights, or contractual or regulatory obligations, that may still be in force after any potentially relevant patents have become unenforceable, and may continue to affect how an invention can be used.**

# Module II

## Identifying technology information needs

### 1. Introduction

This module provides guidance for gathering information from your client about their planned use of an invention, and then organizing the information into a format that can be used as the starting point for FTO searching and analysis. You will need sufficient information to:

- describe the complete invention
- identify features of the invention
- state where and when the client plans to use the invention
- develop an initial set of keywords and search parameters for an FTO search.

This module teaches you techniques and skills to do this.

#### Learning points

Once you have completed this module, you should understand how to:

- Interview clients to gather relevant technical and business information about their planned use of an invention, and organize the information gathered in the interview.
- Carry out a follow-on analysis to identify invention features and draft patent-style claims that recite the essential features of the invention.
- Interpret business information to identify location(s) and time frame(s) for using the invention.
- Collect an initial set of keywords and phrases to use for searching patent databases.
- Use information obtained from the client, and your follow-on analysis, to prepare a Summary Report that will be used in the FTO search and analysis process.

### Helpful hint

Figure 2 can be used as a worksheet that provides questions to ask in an interview, with space to enter the client's answers. However, because clients will approach you with various scenarios that may require different interview techniques and objectives, remember that some of these sample questions may not apply to every client, and additional questions and topic areas may be appropriate in some circumstances.

## 2. Information to be gathered from the client

You will gather information from a client during one or more interviews, and perhaps also through reviewing any documents the client may provide, such as a summary of the invention, results from using the invention, drawings or diagrams, laboratory reports and business-related documents.

Information gathering at this stage should focus on understanding the client's invention and their plans for using it. You will need to gather technical information about the invention in order to be able to design and carry out FTO searches as described in Module III. You will need to gather business information about your client's plans for using the invention, in order to be able to limit the FTO search to the countries where the client plans to use the invention, and the time frames when the client plans to use it.

You will then use your experience in IP and patent matters to prepare a Summary Report describing what the invention is, what features characterize the invention and how the client plans to use it. It is strongly recommended that you try to describe the invention by drafting patent-style claims that recite the essential features of the invention. The Summary Report will form the basis for designing and carrying out an FTO search as described in the next module.

**Strategic interview questions and their objectives are illustrated in the set of sample questions in Figure 2 below.** Using these questions, you will gather two types of information:

- Technical information that enables you to design the right search for the invention.
- Business information that makes the search more accurate and efficient.

### 2.1 Technical information

To gather relevant technical information about the invention, you should start from the viewpoint that *an invention should be a solution to a problem, in particular a technical solution to a problem.*

That means you want to find out about the “problem” that your client is trying to address, and the features that have technical effects that contribute to achieving the “technical solution” to that problem. It is important to learn which features are the *essential features* that produce the technical effects that are necessary for the invention to solve the problem, and which features are optional features. You should explore with your client alternative or equivalent ways for practicing the invention, and collect appropriate documents that may help with the process.

You will also want to identify the background and context for the invention, such as the client's reasons and motivation for pursuing this invention, and the history of other attempts to address the same or similar problems. At the end of this stage, you should be able to describe the invention and characterize its features, and will have an initial set of keywords and phrases relating to the invention, ready to use in the FTO search stage.

**Question 1: Overview of the invention and problem to be solved**

Technical information gathering starts with an overview of the invention and the problem(s) being addressed by the invention. Questions about the client's goals, purpose and hopes will help the client explain what problem(s) they are trying to address. You should gather information that relates to multiple aspects of the problem to be solved, including both technical aspects and business aspects such as the social context of the problem and the reason for planning to use the invention in certain countries.

**Question 2: Technical description of the invention**

The questions in this section will provide an overview of the technical details of the invention.

**Question 2.A: Broad technical description**

Start with a broad, high-level description of the invention that will allow you to summarize the invention and identify the technical field(s) of the invention. For the technical field, you will want enough technical specificity to be able to use this information during the FTO search stage. You may begin by asking the client to identify various technology areas the invention is associated with, and the purpose of the invention, and then narrow the questions as necessary to arrive at a technical field that reasonably describes the invention.

For example, a substance that is derived from bacteria, applied in gel form to a wound and then cured with UV light to form a biocompatible glue that closes the wound and is gradually resorbed by the body as the wound heals, would be associated with the technology areas of medicine, chemistry, microbiology and physics, and the technical field could best be described as "glue for closing wounds" or "biocompatible glue for closing wounds."

In addition, identify the type(s) of invention – device (machine, apparatus), process (method) or product (composition of matter). In some cases, identifying the type of invention provides useful focus. For example, stating that an invention relates to "providing variable amounts of milk" does not distinguish between a controllable milk-dispensing machine, a milk carton with multiple compartments and a new way to milk a cow, whereas stating that an invention relates to "a coin-actuated device for dispensing variable amounts of milk" describes a technical field that provides a basis for searching. There may be multiple types of invention, for example a medical product and a method of making it.

**Question 2.B: Detailed technical description**

Start by having the client describe how the invention is carried out, in detail, from beginning to end. You

should gather specific information about how the invention works by having the client list the components and the steps of the invention.

- **Components** can be ingredients, chemical compounds, structures, structural elements, other elements, materials, devices, mechanical parts, electrical parts, multipart structures, functional blocks of software, research tools and the like. They can include intermediates that are formed during the invention that are used in later steps.
- **Steps** can be processes, methods or actions such as mixing, heating, slicing and selecting, mechanical/electrical functions such as coupling, transmitting, modulating and detecting, or software-controlled executable functions such as summing, sorting and configuring. *Steps of the invention utilize the components of the invention*, so a description of a step will include the process and any components used in that process.

Identify *technical relationships within the invention* by asking questions about how components and steps interact, or work together, when the invention is carried out. Identifying technical relationships between the components and the steps of the invention will help you understand how the invention works in space and over time, which will identify **features of the invention**. This information is useful for "functional deconstruction" of the invention for the FTO search as taught in the next module.

After you have gathered information about the technical effects of using the components and steps of the invention, ask questions about the **end product or result**, and how that product or result represents a solution to the problem. This line of questioning should demonstrate how the technical effects contribute to addressing or solving the technical problem of the invention. What does the client think are the key technical effects that address the problem?

**Questions 3–6: Features and limitations of the invention**

Use these questions to explore the invention in further detail to identify what is required (essential) for the invention to work, and what can be used in the invention but is optional. These questions also explore what can only be described by its function. Questions about relationships and interactions between the components and steps of the invention, and any critical values the client has determined, will help you understand and describe the invention better.

**Question 3: Identify essential features of the invention**

An essential feature is a feature that is required for the invention to work. An essential feature can be a component, a step, a combination of a step that uses a

### Terminology hint

An **essential** feature of an invention is one that is needed to achieve a technical effect that is crucial for achieving the technical solution provided by the invention.

An **optional** feature is one that is included for additional effect(s) but does not contribute directly to the technical solution provided by the invention.

component, a function that is not limited to a specific combination of steps and components, or similar. During the FTO search stage, you can use essential features to define the minimum requirements of the invention. During the FTO analysis stage, this will help you consider whether a claim could be interpreted to cover (read on) some or all of the essential features of the client's invention.

#### **Question 4: Identify optional features of the invention**

Optional features may be useful during the FTO analysis stage, to compare patent claims with various ways of practicing the client's invention. For example, the client could decide to omit optional features if they might cause potential FTO issues.

#### **Question 5: Identify functional features of the invention**

A functional feature is a function or an intended result that is described without reference to specific components and/or steps. If you identify functional features, you may wish to explore structure-function relationships to identify ways to implement these features, in order to design effective search strategies for the FTO search stage.

#### **Question 6: Identify significant limits and critical values**

Questions about limits and critical values will help you define the invention more precisely. This precision will help to focus the FTO search to find potentially relevant patent documents, and may help to exclude irrelevant documents. During the FTO analysis stage, limitations and critical values of the client's invention may be important for determining whether a claim might cover, or might not cover, or clearly does not cover, the client's invention.

- **Significant limits** can be limits on the field of the invention, or limits on components, steps or features. Examples include:
  - an invention that provides improved gears that only work for bicycles and not motorized vehicles
  - a component that fastens two metal pieces and must be electrically conductive such that metal fasteners, or glue or plastic fasteners made with conductive polymers, are suitable, but wood or rubber fasteners are not suitable
  - a step of cleaning up digital signals by clipping high and low parts of an incoming signal, such that a limiting function is suitable but a first-order filtering function is not
  - a feature of blending three solid components over a boiling water bath, such that the components must melt at temperatures below 100°C and form a homogenous mixture.
- **Negative limits or exclusions** can be used to identify components, steps or features that are *not* part of the invention. During the FTO search stage, negative limits can be useful to design a search that rejects patent documents with claims that have some of the features of the invention but also require components, steps or features that are not found in the client's invention.
- **Critical values or ranges** impose more precise limits on the invention. Critical values can be *quantitative* (e.g., specific ratios of components, maximum temperatures or time periods for steps, minimum required changes in amperage or voltage between steps or defined values for the properties of an end product). Critical values can be *descriptive* (e.g., heating a mixture until it melts, cooling something to room temperature or detecting changes in



color, physical state or transparency that indicate the presence of a component or the completion of a step). Critical ranges with upper and lower limits can result from a combination of critical values, where a lower limit may be determined by a critical value for one feature of the invention, and the upper limit may be determined by a critical value of a different feature. An example of a critical range would be:

- For an invention that encases a water-containing component in polyethylene (PET plastic), the inventor has determined that the critical range for the encasing step is from 85°C to 95°C, which is hot enough to melt the PET but not hot enough to damage the component by causing the water to boil.

**The absence of known limits is also useful information.** The client may tell you that they did not test a component or step or feature to find out whether there were significant limits, or critical values or ranges. In that case, the component, step or feature will be searched without limitations.

#### **Question 7: Expand scope**

These questions help you gather information about different ways of practicing the invention, and they will provide additional information such as keywords and features to be used for FTO searching, ensuring that the FTO search is sufficiently broad.

**Equivalents** can include:

- **Synonyms** for the components and steps that the client has described. This could include asking the client to identify trade names or generic names of products or processes.
- **Substitutions** for components or steps. Find out if any components or steps can be changed or substituted in the invention, such that the problem is addressed in the *same* way as in the original description, but using different components or steps.

**Alternative ways of practicing the invention** address the problem in a *different* way than the one specified in the client's original description. During the FTO analysis stage, having information about alternative ways of addressing the problem may help you identify which of these ways trigger potential FTO issues, and which of these ways avoid them. In some circumstances, the alternative ways of addressing the problem may differ from the client's original description of the invention to an extent that represents a different invention, and that may require a separate FTO determination.

You should identify **commercial products or processes used in the invention**. Use of commercial products or processes should be distinguished from

the ordinary use of equipment or standard chemicals. Commercial products can be used as components (e.g., as key ingredients), or as preassembled structures (such as motors or circuit boards), that are essential to the invention. Commercial processes can include preassembled kits for performing essential steps (e.g., if an invention requires measuring a substance and the client uses a commercial testing kit to detect and measure the substance). Commercial products or processes may be a good source of keywords, and if patented, can be a source of information about the technical field, related technical fields and patent classification symbols for similar inventions. It is important to learn the generic name of any commercial products or processes (and the source, if possible) to be included as additional keywords or phrases.

During an interview, you will not know in advance what might be an equivalent way of practicing the client's invention and what might be an alternative, or what commercial products or processes might be involved. Therefore, ask open-ended questions that allow the client to report or speculate about different ways to practice the invention, in order to expand the scope of information you gather.

#### **Question 8: Additional information and documents, and non-text features**

By asking about different kinds of documents that relate to the invention, you may gather additional useful information that the client might not have considered relevant otherwise. Technical documents such as drawings, diagrams, flowcharts, or circuit layouts can enhance understanding of the invention, and they are sometimes essential to understanding non-text features of the invention that are difficult to express using words alone. Results from testing or optimization may clarify some of the features of the invention, or establish limits or critical values or reveal equivalents and alternatives. Documents relating to making or manufacturing may explain technical details of essential features. Documents relating to selling or commercializing may include descriptions of the intended effects of using the invention, which can provide additional information about how the invention addresses the problem.

**Non-text features.** The invention may include non-text features such as drawings, flowcharts, chemical structures, wiring diagrams, protein or nucleotide sequences or chemical structures.

- Identify any **searchable non-text features**. These are chemical structures (including polymers), nucleotide sequences, or protein sequences that can be searched for in specialist databases. These features will require separate search strategies.
- Flag **other non-text features** that are important

but may not be searchable, such as drawings of a machine or device, method flowcharts, process flowcharts, diagrams, wiring diagrams, computer component layouts (e.g., a chip or board), computer program flowcharts, or block diagrams of network layouts. These features can be used during the FTO analysis stage for comparison with drawings, claim images, or specifications in the patent documents that were identified by the FTO search.

### **Questions 9 and 10: Background and context of the invention**

Questions about the background and context of the invention can supply distinct types of useful information. Information about potential competitors, collaborators or third-party IP could provide targeted search terms and patent classification symbols for the FTO search. Information about similarities, or inventions that the client used as inspiration, may indicate that the client has made an improvement to an earlier patented invention that could be found during the FTO search.

Information about key differences may be useful during the FTO analysis stage, when the client's invention is compared with the claimed invention of a patent document that was identified by the FTO search, and these differences may help you determine whether or not the client's invention is sufficiently distinct from the claimed invention.

## **2.2 Business information**

You also need to gather business information about the client's plans for using the invention. Some of this information will tell you when and where the client plans to use the invention. Some of this information will also tell you how the client plans to use the invention in each country, which will be important when you are comparing the client's invention with construed claims during the FTO analysis stage.

### **Question 11: Client's plans for using the invention**

You need to gather business information about the client's plans for using the invention. The appropriate scope of questions will depend on the nature of the invention and the client's plans, so you should decide which questions to ask on a case-by-case basis, for example about manufacturing, licensing or IP.

The main objective is to learn *where* and *when* the client plans to carry out different activities, so that you can focus the FTO search to find patent documents in the relevant countries and time frames. This information can also be important for FTO analysis, such as where

you find a potential dominant patent in one country of planned use but not in another country, indicating country-specific potential FTO issues the client may encounter. Likewise, you may find a potential dominant patent in one country of planned use, but information about the client's timing may allow you to determine that the client will not start using the invention in that country until after that patent is calculated to expire, so FTO issues relating to that patent should not arise.

You may have also received information about plans for financing, licenses, collaborations, joint ventures, supply chains, distribution arrangements, ownership of IP, other types of IP associated with the invention or other activities. These plans may impose significant obligations that the client will have to satisfy in order to be free to use the invention in the way(s) they have planned. However, evaluating these business plans and arrangements are beyond the scope of this guide, which is limited to using tools of FTO search and analysis.

### **Recap**

**To carry out an FTO search you need sufficient information to:**

- describe the complete invention
- identify features of the invention
- say where (which countries) and when the invention may be used
- define keywords and parameters to use in a search.

**Information gathering should focus on understanding the invention and the client's plans for it.**

**Interviewing clients is the best way of gathering information, but information can also be collected from documents provided by the client, such as:**

- a summary of the invention
- results from using the invention
- drawings or diagrams
- laboratory reports
- business-related documents.

**Both technical and business information are required.**

**Information about the background and context of the invention is also useful.**

Figure 2: Sample questions for gathering information about the client's invention

Objective	Sample interview questions
<b>Part A. Technical information: Invention overview, details, background</b>	
1. Overview: goal, purpose, plans  Problem to be solved	<p>What is the problem being addressed or solved? What is the goal or purpose of the invention?</p> <ul style="list-style-type: none"> <li>– What does the client hope to accomplish with their plans for using this invention?</li> <li>– For an inventor: What was the inspiration for developing this invention?</li> <li>– For a client interested in further developing, commercializing or distributing the invention: What inspired or attracted the client to this project?</li> </ul>
2. Technical description of invention  A. Technical field(s) and type(s) of invention  B. Technical details of the invention  Components and steps  Technical relationships between components and parts – physical, temporal, functional  End result	<p>Describe the invention in technical terms.</p> <p>A. Broad technical description:</p> <ul style="list-style-type: none"> <li>– What is the <b>technical field</b> of the invention?</li> <li>– What <b>type(s) of invention</b> does the client use to address the problem? Device? Process? Product?</li> </ul> <p>B. Detailed technical description:</p> <ul style="list-style-type: none"> <li>– Describe the invention from beginning to end. <ul style="list-style-type: none"> <li>· What <b>components</b> are used?</li> <li>· What <b>steps</b> occur in the invention?</li> </ul> </li> <li>– How do the components and steps <b>interact (work together)</b> in the invention? <ul style="list-style-type: none"> <li>· What interactions occur between components?</li> <li>· What interactions occur between steps?</li> <li>· What interactions occur between components and steps?</li> <li>· When do these interactions take place during the course of practicing the invention?</li> </ul> </li> <li>– What is the end result of the invention?</li> <li>– How do <b>technical effects</b> of the components and steps address the problem and/or accomplish the purpose?</li> </ul>
3. Essential features	<p>What is <b>required</b> for the invention to work (i.e., the <b>essential features</b>)?</p> <ul style="list-style-type: none"> <li>– What are the required components and required steps?</li> <li>– What interactions are required?</li> </ul>
4. Optional features	<p>What components or steps can be included, but are not required to practice the invention (i.e., <b>optional features</b>)?</p>
5. Functional features (can be essential features or optional features)	<p>Does the invention include a function to be performed, or a result to be achieved, without identifying component(s) or step(s) that perform the function or achieve the result (i.e., <b>functional features</b>)?</p>
6. Significant limits  Critical values and ranges	<p>Has the client identified significant <b>limits</b> for components, steps, features or the invention as a whole?</p> <ul style="list-style-type: none"> <li>– Does the invention only apply to certain situations? <ul style="list-style-type: none"> <li>· Does the invention work only when certain types of components are used?</li> <li>· Does the invention work only when certain steps are carried out in a specific way?</li> <li>· Are there components or ways of practicing steps that must not be used?</li> </ul> </li> <li>– Have <b>critical values or ranges</b> been identified for any of the components or steps?</li> </ul>
7. Equivalents and alternatives  Use of commercial products or processes	<p>What are different ways to practice the invention?</p> <ul style="list-style-type: none"> <li>– What <b>equivalents and alternatives</b> has the client tested or considered? <ul style="list-style-type: none"> <li>· What can be substituted and still get the same result?</li> <li>· What produces a different result when substituted?</li> </ul> </li> <li>– Does the client use <b>commercial products</b> as components, or <b>commercial processes</b> (including kits) to perform steps?</li> </ul>

---

8. Documents as a source of additional information; non-text features	Does the client have <b>documents</b> such as an invention disclosure, drawings, diagrams, chemical structures, sequences, results from testing or optimization, research about other approaches to solving the problem or non-confidential business documents relating to making, manufacturing and selling? Do any of these documents show <b>non-text features</b> of the invention?
9. Background information  Source of additional search terms, and may suggest patent classification symbols	What does the client know about how the problem has been addressed or solved in the past? <ul style="list-style-type: none"><li>– Can the client identify other existing inventions that have addressed or solved the problem?</li><li>– Can the client identify other parties (companies, individuals, programs) that have tried to address or solve the problem?</li><li>– Is the client aware of relevant IP owned by other parties?</li></ul>
10. Differences and distinguishing features	What are the key differences between the client’s invention and any other inventions or approaches to the problem? <ul style="list-style-type: none"><li>– How does the client’s invention solve the problem, compared with other approaches to the same problem or similar problems?</li><li>– What made the client decide to take this approach to this problem?<ul style="list-style-type: none"><li>· What choices did they make to do things differently?</li><li>· What do they think is their original contribution?</li></ul></li></ul>

---

**Part B. Business information: Where and when does the client plan to use the invention?**

---

11. Where and when  Countries to be searched and time frames to be searched  Subject matter specific to countries or time frames	What does the client plan to do with the invention? In what country or countries, and when? <ul style="list-style-type: none"><li>– Does the client plan to engage in product development and testing?</li><li>– Does the client plan to manufacture? Where and when?</li><li>– Does the client plan to sell or license a product? A device? A process or method? Where and when?</li><li>– What discussions are they having, if any, with other parties such as suppliers or distributors? Where and when?</li><li>– Even if they are not currently planning to operate in a major market like the United States of America, Europe, Japan or China, do they think there is a possibility that there would be interest in any of those markets? If so, when?</li></ul>
--	---

---

### 3. Follow-on analysis and Summary Report

Follow-on analysis starts by reviewing your interview notes and any documents provided by the client, and deciding whether you need to carry out additional research to understand the client’s invention. The next step involves organizing the information you have collected about the invention. Consider various organizing approaches, such as text, outlines, figures, diagrams or flowcharts, to convey the information in useful ways. Finally, use the guidance above at 2.1 and 2.2 about the type of information needed to address each topic, and develop the invention description and other answers that will be entered in the Summary Report.

For example, review the client’s answers to Question 3 about what is required for the invention to work, and Question 4 about what is optional, and develop descriptions of the essential and optional features of the invention. During the interview, the client may not be able to answer Question 5 about functional features, but your follow-on analysis may allow you to identify any functional features of the invention. To complete the background information (Question 9) and important differences (Question 10), you may incorporate information from client remarks made throughout the interview, and not just in response to topic-specific questions. You may need to analyze answers about business information (Question 11) to understand what activities are planned for which countries and when.

**To prepare the Summary Report, use the template provided in Annex A.2.** This template is arranged to help you capture information from your interview notes and follow-on analysis. The left column shows how the template format corresponds to the questions in Figure 2, and the right column indicates the type of information that should be entered, based on client answers and any follow-on analysis. Part A of the Summary Report relates to technical information (Questions 1–10), Part B relates to business information (Question 11) and Part C provides for additional products of follow-on analysis, such as an initial set of keywords, patent-style claims to describe the invention, and additional comments or materials you want to include.

#### 3.1 Summary Report Part A. Technical information

It is crucial to have a clear understanding of the technical details of the invention and its features, because you will rely on this understanding for the remainder of the FTO determination process. Follow-on analysis of the technical information you gather involves reviewing the answers to Questions 1–10 and any relevant documents and additional research, and then formulating answers to the corresponding sections of the Summary Report.

Start by preparing an answer for the first instruction in Part A Question 2.B of the Summary Report: “Provide a summary of the invention that describes how the invention is carried out from beginning to end.”

Complete Question 2.B by entering lists of components, steps and functions, along with your description of how they work together.

#### Helpful hint

Answering Question 2.B in Part A of the Summary Report may help you answer other questions such as the problem to be solved (Question 1), or the technical-field(s) of the invention.

As discussed above, your follow-on analysis should allow you to identify essential features (Question 3), optional features (Question 4), functional features (Question 5), non-text features (Question 8) and technical details such as critical values or limits (Question 6) and equivalents (Question 7). You should enter technical information wherever appropriate, which means some information may be entered more than once. For example, essential features (Question 3) should include essential functional features and essential non-text features; any essential functional feature should therefore be listed in response to Questions 3 and 5, and any essential non-text figures should be listed for Questions 3 and 8. Similarly, background information (Question 9) and important differences (Question 10) may repeat goals, motivations and problem(s) to be solved (Question 1), or even technical details of essential features (Question 3) or critical limits (Question 7), that have already been entered in other parts of the Summary Report.

### 3.2 Summary Report Part B. Business information

In Part B of the Summary Report, enter the business information you have organized in the form of a list of countries for FTO search and, for each country, a list of projected dates of use. The projected dates of use refer to the time the client thinks they may begin to use the invention in a country, and will usually not include an end date. If the client plans different activities in different countries, it is important to list what activities are planned for each. This part can include follow-on analysis of the relative importance of different countries as potential target markets.

### 3.3 Summary Report Part C. Additional analysis

#### Initial set of keywords and phrases

Review your interview notes and the analysis of technical information you prepared for Part A of the Summary Report, and collect an initial set of keywords and phrases relating to the invention. These keywords and phrases will include components of the invention, and may include steps.

#### Optional but recommended: Draft patent-style claims to describe the invention

One of the most useful ways to organize invention information is to use patent-style claims to describe

the client's invention. Using your familiarity with patent documents, try drafting at least one broad independent claim that describes the invention using all of its essential features – all of the components, steps and interactions that are necessary for the invention to work. Narrower dependent claims could recite details of specific ways the client thinks the invention can be practiced, such as optional features and different embodiments of the invention. List these claims at Part C of the Summary Report. Teaching Example 7 provides an outline of the process of drafting a patent-style claim.

You can use information from Part A 2.A of your notes to identify the type of invention and its purpose (the “pre-amble” of the claim), and information from 2.B and 3 to identify the essential features of the invention described in terms of the components and steps that are required for the invention to work (the “body” of the claim). A claim-style description therefore reads as follows:

#### For a process claim:

*A [type of invention] for [purpose of the invention, or main technical effect], comprising: [[list components that are required for the invention to work],*

*wherein [describe each required step and the components used in that step, in order of occurrence, including any significant limits or critical values, and any functional features that are essential].*

#### For a product claim:

*A [type of invention] for [purpose of the invention, or main technical effect], comprising: [describe components that are required for the invention to work and how they are combined, including any significant limits or critical values, and any functional features that are essential].*

For dependent claims, you can include optional features as additional claim limitations, or limit the components or steps to the exact way the client practices the invention. Dependent claims can include a “picture claim” that recites specific details of the client's way of practicing the invention, which can be useful during the FTO analysis stage.

This exercise may help you define how components and steps interact to produce technical effects that are features of the invention. This understanding may help you design search strategies to find patent documents that disclose at least some of the features of the invention, and avoid finding large numbers of irrelevant patent documents.

### Teaching Example 7: Gathering information and drafting patent-style claims

An inventor says she took well-known organic compounds X and Y, mixed roughly equal amounts of X and Y, heated the mixture to 70°C for 10 minutes and allowed it to cool at room temperature before adding “a pinch” of organic compound Z to make a final homogeneous mixture that can be used as a binder for holding two pieces of non-porous metal together.

**Problem being addressed:** Obtaining a stable combination of organic compounds X, Y and Z to be used as a binder for metals; preparing an organic binder using compounds X, Y and Z that is capable of binding metals.

**Technical field:** Binders for metals; binders for non-porous materials; organic materials that can bind metals; metallurgy.

**Type of invention:** Method (process).

**Description of invention:** See above.

**Components:** Compound X, compound Y, mixture of X and Y, compound Z, end product XYZ.

**Steps:** Mix compound X and Y, heat the mixture of X and Y, cool the mixture of X and Y, add compound Z, mix X, Y and Z thoroughly.

**Essential features:**

- Mixing X and Y and heating the mixture of X and Y.
- Cooling the mixture of X and Y to room temperature.
- Adding Z to cooled mixture of X and Y at room temperature.

**Critical ranges or values?** The client did not test different amounts of compounds X, Y and Z. She used X and Y in equal amounts, but did not test other ratios. She measured the temperature once, and the mixture of X and Y was about 70°C, which means heating to 70° is sufficient but no critical range of temperatures has been identified.

She heated the mixture for about 10 minutes, but she did not test longer or shorter times. She did not test whether the binder worked on other non-porous materials besides metal. She tested different conditions for adding compound Z and reported that the invention did not work when she added compound Z while the mixture of X and Y was still hot, but only worked when the mixture of X and Y was cooled to room temperature before adding compound Z, which means *cooling the*

*mixture of X and Y to room temperature before adding Z is a critical value.*

**Initial set of keywords and phrases:** X, Y, mixture of X and Y, Z, XYZ, organic binder for metals.

**Possible broadest claim-style description of the invention:** A method of preparing a binder for non-porous materials comprising: combining compound X and compound Y to form a mixture, heating the mixture, allowing the mixture to cool to room temperature, adding compound Z to the cooled mixture and mixing thoroughly.

**Possible narrower claim-style description:** A method of preparing a binder for metals comprising: combining approximately equal amounts of compound X and Y to form a mixture, heating the mixture to about 70°C for about 10 minutes, allowing the mixture to cool to room temperature, adding compound Z to the cooled mixture and mixing thoroughly, wherein the combination of X, Y and Z is capable of binding two metal pieces.

This is an informal exercise in organizing information about the invention, so many of the concerns that apply to drafting claims for a patent application do not apply here. You are not writing claims for a patent application so you *do not* have to use formal claim language or try to identify patentable features, because FTO searching is not concerned with patentability. For more information and guidance about claim drafting, you can consult the *WIPO Patent Drafting Manual* (see Annex D).

## 4. Conclusion

You must construct a complete technical description of the invention, and describe the client's plans to use the invention, in a format that will allow you to:

- deconstruct it during the FTO search stage to develop a broad search strategy to find patents that may cover any feature of the invention
- compare it with patent claims during the FTO analysis stage.

The Summary Report is organized in a way that allows the appropriate information to be extracted for FTO search and FTO analysis.

### Recap

**After interviewing your client, you may need to carry out further research to help you fully understand the client's invention.**

**A Summary Report forms the basis for designing and conducting an FTO search.**

**Your Summary Report should describe:**

- what the invention is
- what features characterize the invention
- how, when and where the client plans to use it.



# Module III

## FTO search: Finding sources of information to identify inventions in the public domain and carrying out an FTO search

### 1. Introduction

This stage involves searching for patent documents with claims that cover subject matter that may be relevant to your client's invention. You will need to search for patent documents with claims that are relevant to any of the features of the invention. Your goal is to design a search that will generate results with a high proportion of potentially relevant patent documents that disclose and claim at least one feature of the invention, and as few irrelevant documents as possible.

During the search process, you will continually need to find a balance between recall (breadth), to find as many potentially relevant documents as possible, and precision, to find the most relevant documents. This guide teaches a "hybrid" approach to balancing recall and precision in an FTO search using different types of search inputs. Keywords are used to search for documents using similar terms, and patent classification symbols are used to focus the search on relevant technology areas. This combination allows each type of search input to complement the potential weaknesses and reinforce the strengths of the other type. You will also learn about tools and enhancements to supply additional search inputs. You can use your own technical knowledge and common sense, and tools such as disambiguation functions, to decide what limitations on breadth achieve a desirable level of precision. Searching is an iterative process that may require multiple rounds of testing to improve the quality of the search results.

#### Learning points

Once you have completed this module, you should understand how to:

- Deconstruct the invention and develop an expanded list of keywords and phrases to use as search inputs.
- Find patent classification symbols related to the invention.
- Find sources of information (databases, technologies and additional terms) and tools to help carry out an FTO search.
- Design and test search strings and strategies.
- Make decisions about what limitations are appropriate for the FTO search to be specific and focused enough to retrieve potentially relevant patent documents.
- Carry out an FTO search and identify potentially relevant patent documents.
- Prepare an FTO Search Report.

## 2. Preparation for search: Deconstructing the invention

The pre-search activities described below deal mainly with initial characterization and deconstruction of the invention to generate keywords and phrases. You will carry out these activities to generate inputs that can be used to search patent databases.

### 2.1 FTO search to find potential dominant patents

The FTO search must be broad enough to retrieve as many potentially relevant patent documents as possible, if any exist. Therefore, you need to deconstruct the invention into its parts and essential features, and then describe each part and feature in a broad generic way. Parts of the invention include the type of invention (product or process), the goal or problem being solved and features of the invention that contribute to producing the technical effect that provides the new approach or technical solution of the invention. Deconstruction should produce a comprehensive set of keywords and phrases that you can expand into a search query to match more patent documents.

You need to be able to describe the invention in terms of its essential features – what is absolutely necessary for the invention to accomplish its function. Review the summary of the invention in your Summary Report from Module II, and decide if this is a comprehensive description of the invention that:

- recites all the components, steps and functions that are necessary for the invention to work (all the essential features)
- does not recite any feature that is optional and can be omitted.

If you wrote at least one claim-style description of the invention, review the broadest claim and decide if it is a comprehensive description that includes all of the essential features and does not include any optional features.

This focus on the essential features of the invention reflects the basic principle of infringement analysis:

If all of the features of a patented invention defined in a claim (in the “claim elements” or “claim limitations”) can be found in a later invention, then the claim covers (reads on) the later invention and practicing the later invention infringes the claim (and the patent).

As discussed in Module I, a dominant patent will cover (read on) a later invention if the later invention includes the patented invention of the dominant patent as a feature, even if the later patent also includes other features that are not found in the claims of the dominant patent. Therefore, your search strategy must be designed to search for each essential feature, in order to find *any* patent documents that cover *any* essential feature of the client’s invention.

#### Helpful hint

If the client provided a diagram or process flowchart for the invention, this can be a useful resource for deconstructing the invention and generating a high-level, functional diagram of a system for implementing a generic example of the invention.

#### Principles of deconstruction

Deconstruction requires you to *formulate a broad “generic” description of how the invention solves a problem*, rather than focus on the

details of the specific implementation that the client wants to use. The process of deconstruction focuses on the features that accomplish the technical effect(s) of the invention. The features are generalized and expressed as broader concepts (sometimes called “operative features”) or as a generic deconstruction of the invention. These broader concepts may be expanded to include classes of components or steps that perform a similar function.

In order to practice this approach, you need to isolate each of the features that could be used to implement a generic example of the invention. The goal is to identify the components, steps and functions of a generic implementation of the invention, and to do so using high-level and non-specific language.

The result of this approach will be a list of the components, steps and functions that are needed to implement a generic version of the invention. For functional features, you should determine how different properties can achieve a function, and how different functions can achieve a property of the invention, to generate a list of properties and functions that achieve the effect that the functional feature plays as part of the invention.

Practical tools for visualizing deconstruction include diagrams or lists. Figure 3 shows an abstract overview of how an invention having a collection of “features” may be deconstructed, showing different types of features present in an invention, possible combinations of those features and relationships between them.

**Figure 3: Deconstructing an invention**

**Features**

- **Device**
  - Form
  - Parts, structure
  - How it functions
  - The effect it produces
- **Process**
  - Sequence of steps
- **Combination of devices and process**
  - Has an end product
  - Does not have an end product
- **New chemical substance**
- **New use for a known substance**

As the diagram shows, you may identify essential features such as the following:

- A device or any product that can be broken down into component parts.
- A process (step) that has a sequence of steps (subprocesses).
- A combination – the invention may be a combination of a device (component) and one or more processes (steps), or a combination of components (ingredients) and processes.
- A chemical substance – these belong to chemical classes of structure and function, and there are special strategies for their deconstruction.

You have to decide how broad (generic) or narrow (precise) the deconstruction needs to be. Your common sense and technical knowledge are important resources for this decision, as you have to balance the requirements of precision and recall depending on the complexity of your purpose. It will also be important to decide when to stop the deconstruction, for example if the client practices a feature using a multipart commercial product that is “out of the box” it may not need to be deconstructed further. If the client or the searcher is confident that the feature is a public domain invention in the target countries, then that feature will not need to be deconstructed further.

**Deconstructing components of an invention**

When an invention comprises components *and* steps (processes), you should carry out deconstruction separately for each. Note that some claims to novel products, such as chemicals or compositions of matter, *only* recite components.

Here, the aim is to decouple each component to allow inspection of each in its own right. To find *any* patent documents that cover *any* essential feature of the client’s invention, you need to look for each component separately, decoupled from the other components and decoupled from the invention steps.

Deconstruction can be illustrated using the invention from Teaching Example 7 in Module II, which involves mixing compound X and compound Y, heating the mixture of X and Y (intermediate XY), cooling the mixture of X and Y, and then adding Z to yield the end product XYZ. The invention can be depicted as:

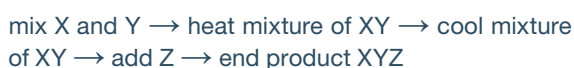

The invention can be deconstructed into all of its components, with each component shown separately:

- X
- Y
- Z
- XY
- XYZ.

Result: You have decoupled the end product XYZ from component X, from component Y and from component Z. You have decoupled intermediate product XY from X and from Y. This decoupling allows you to find patent documents that claim X or Y or Z or XY or XYZ, any of which might cover (read on) this invention.

### Deconstructing steps of an invention

Here, the aim is to decouple each step (process) from every other step in the invention, so as to allow inspection of each step in its own right. To find *any* patent documents that cover *any* essential feature of the client's invention, you need to look for each step decoupled from the other steps, and decoupled from the invention components.

Using the same example as above, an invention is depicted as:

mix X and Y → heat mixture of XY → cool mixture of XY → add Z → end product XYZ

The invention can be deconstructed into all of its steps, with each step shown separately:

- Mixing X and Y
- Heating XY
- Cooling XY
- Adding Z to XY.

Result: You have decoupled the steps from each other. In the actual practice of the invention, some of these steps are coupled, because heating XY requires the previous step of mixing X and Y. However, for FTO search purposes, you have to decouple the steps in order to find patent documents that claim *any* of these steps.

### Composite components and composite steps may need further deconstruction

During deconstruction, it may become clear that the components and steps are “composite components” or “composite steps” that can be broken down further into additional components and steps. Consider the difference between a step identified as “heating” a mixture and a step identified as “distilling” a mixture. Heating a mixture is probably a single step, while

distilling a mixture should be treated as a composite step that includes a first step of heating a mixture and a second step of collecting separated components of the mixture.

### Deconstructing functional features

An invention may include functional features. A functional feature is a feature described in terms of a function or a result to be achieved, without reference to specific components or steps for carrying out that function. If you identify functional features, it is important to explore structure-function relationships to identify ways to implement these features.

You may have identified functional features in the summary of the invention, or in the patent-style claims. Functional features sometimes become apparent from non-text elements such as drawings, prototypes, flowcharts and diagrams that show how the invention is assembled or how the process steps are arranged.

You can identify functional features using interview Question 5 (Figure 2 in the previous module), which is as follows:

Does the invention include a function to be performed or a result to be achieved, without identifying component(s) or step(s) that perform the function or achieve the result, (i.e., functional features)?

Further, Question 2.B arrives at the technical details of the invention by asking:

How do the components and steps interact (work together) in the invention? (This explores the structure-function relationships to achieve a result.)

## 2.2 Expanded list of keywords and phrases to use in search queries

Deconstruction of the invention should generate a comprehensive set of results that you can use to build a list of keywords and phrases. The results should be comprehensive because you will have identified *all* the essential features of the invention, and *all* of the components, steps and functions that are required to accomplish the work of the invention.

The next step is to *expand* the list to increase the probability of finding relevant patent documents. This should give you an expanded keyword set that covers *all* of the features of the invention, and which can be used to develop search queries.

### Find synonyms or equivalents

Start expanding the keyword list by looking for synonyms or equivalents for the components (ingredients) and the steps (processes) of the invention. When you look for synonyms of a keyword, you may want to find synonyms that are broader and synonyms that are narrower. Start with any synonyms or equivalents you listed in the Summary Report from Module II.

You may want to consult other sources for synonyms and equivalents related to the invention, such as reports or papers or other patents that the inventor has identified, or that you have found in a quick preliminary search. Reference materials are another good source, such as dictionaries, thesauruses or encyclopedias.

### Expand keywords: Structural expansion and functional expansion

Components and steps of an invention can have a structural aspect and a functional aspect. For example, in an invention that uses specific components to achieve a final effect, a component has a structural aspect related to what the component is, and the component may also have a functional aspect related to what the component does. The same can be true for steps and functional features. Therefore, you need to expand the concept found in a keyword using **structural expansion** and **functional expansion** of keywords.

For example, a client's invention is a drug comprising acrivastine (an antihistamine allergy blocker) and aspirin to combat allergic symptoms. Aspirin expands *structurally* into hydrobenzoic acids and it expands *functionally* into the general class of pain relievers or analgesics. Similarly, acrivastine expands *functionally* into the general class of antihistamines and *structurally* into the general class of alkylamines. (See the discussion of searching chemical compounds below.) Thus, expanded descriptions of the client's invention include: a drug comprising a hydrobenzoic acid pain reliever and an alkylamine antihistamine; a drug comprising a hydrobenzoic acid and an alkylamine; or a drug comprising a pain reliever and an antihistamine. These are not just synonyms, but represent relevant combinations that are more broadly claimed than in the original disclosure.

### Expand from specific concepts to general concepts

Consider broadening specific concepts to general concepts, to ensure that more broadly claimed combinations are covered. For example, steps in a water purification technology can be expanded from a specific concept, represented by a step in the invention, to a general concept related to the step.

thin film evaporation → by distillation or evaporation → treatment of water

using surface aeration → activated sludge processes → treatment of waste water

### Terminology hint

Terms such as **means for** or **means** are often used to indicate a functional feature. An example is provided in the European Patent Office (EPO) Guidelines for Examination:

“For example, ‘terminal position detecting means’ in a claim might be supported by a single example comprising a limit switch, it being evident to the skilled person that e.g. a photoelectric cell or a strain gauge could be used instead.” (EPO Guidelines for Examination, Part F, Chapter IV, Section 6.5.)

### Helpful hint

Deconstruction of functional features involves identifying the functional feature and using keywords that express the concept of the functional feature. However, you may find that patent classification symbols are more useful than keywords. Patent classification symbols are based on technical features so they should identify the functional feature, independent of the language used to describe the feature, and independent of what components or steps might be used to achieve the function.

### Helpful hint

Broader synonyms should include terms that describe a class of components or steps within the deconstructed features. For example, if the client's invention discloses **boiling** components, you should think about *broader* synonyms that describe the class of processes including boiling, which could lead you to **heating** as a synonym. This may help you find patent documents with claims that cover the genus that relates to your key term, even if the claims refer to other members of the genus (hyponyms). In the example above, **heating** is a broader synonym for **boiling** and therefore should find patent documents that use the term **incubating** in the claims.

Again, these are not synonyms. By expanding keywords or phrases into general concepts, you have increased the potential for finding relevant patent documents directed to the same technological concept, even if they use different words.

This expansion step does not have to be exhaustive. As you will learn later, there are tools for “query expansion” that suggest additional keywords and phrases (e.g., WIPO Pearl) to find similar ways of describing a feature based on actual language already used in patent documents. Tools such as Cross-Lingual Information Retrieval (or cross-lingual expansion) (WIPO CLIR) can translate keywords into other languages. In addition, use of patent classification symbols based on a technology area may find documents that use different words to describe the same thing. These tools provide support for finding potentially relevant patent documents, so that the effectiveness of the FTO search does not depend entirely on your ability to find synonyms of keywords.

### Test keywords for relevance

You may want to quickly test the relevance and applicability of the keywords and the phrases you are collecting. For example, you may have discussed the invention with your client using a local or regional way of referring to a mechanical device that is used in the invention, such as describing a hot water heater as a “geezer” or “geyser,” but that word or phrase may not be widely used. You can quickly check a free patent database such as PATENTSCOPE to determine whether a term is actually found in patent documents. Otherwise, you should find and use standard synonyms for the term.

### Expanded keyword set

On completing this step, you will have expanded the original list of isolated components, steps, and functions you identified by deconstruction, to arrive at an **expanded keyword set**. Teaching Example 8 illustrates the process.

## 3. Patent classification symbols associated with the invention

Patent classification symbols can be a convenient and effective method of retrieving patent literature on a given subject. Patent classification systems provide hierarchical systems for classifying patents according to the areas of technology to which they pertain, using language-independent symbols for patent classes and subclasses. Patent classification symbols can be assigned for reasons related to the technology and technical area(s) involved, the types of components or steps used in the invention or the technical problem(s) to be solved. Most patent documents are assigned multiple patent classification symbols, to reflect different aspects of the invention and related disclosures found in the document.

As taught in this guide, *patent classification symbols can be used very effectively when combined with other search terms such as keywords, chemical structures, and keywords and phrases in different languages (using cross-lingual expansions of search terms) in a*

### Teaching Example 8: Deconstruction and expansion to generate an expanded keyword set

A client has formulated a wood polish to protect outdoor wooden furniture from the sun. It is made of an acrylic resin fortified with nano-zinc oxide.

**Deconstruction** of the invention produced a list of essential features:

- **Components:** Zinc oxide; nanoparticle; wood polish; acrylic resin.
- **Functional feature:** Protection from sun.

**Expansion:** You expanded the list with synonyms for words and phrases. Structural and functional expansion provided additional words and phrases. Structural expansion of wood produced “wooden furniture” which is appropriate for this invention. For the component identified as “polish” (as a noun), a synonym is “coat” (noun), and functional expansion identified functions including the verbs polish, coat, treat and impregnate. Deconstruction of the phrase describing the feature “protect from sun” produced synonyms for the protection function and synonyms for “sun” while structural expansion of “sun” (in the context of protection) produced words referring to the damaging UV wavelengths in sunlight.

#### Expanded keyword set:

- **zinc oxide** or ZnO or Zn oxide
- **nanoparticle** or nanotechnology or nano or nanoscale or nanosize or nanostructure or nanocrystal or nm or nanometre or ultrafine
- **wood** or timber
- **polish** or coat or treat or impregnate or preserve
- **acrylic** or acrylate or polyacrylic or polyacrylate
- **resin** or lacquer
- **protect from sun** or photoprotective or photoprotection or ultraviolet or UV/UVA/UVB or light or sunlight or absorbing or absorption/absorbing or stabilizing or photostabilization or photostabilization or filter.

### Teaching Example 9: Finding International Patent Classification (IPC) symbols using an expanded keyword set

For the wood polish example on the left, the essential features (technology categories) and expanded keywords were used to find relevant IPC symbols.

Essential features: technology categories	Keywords	IPC symbols
Zinc oxide	ZnO or zinc oxide or Zn oxide	C09C1/04, C01G9/02
Nanoparticle or nanotechnology	Nano or nanoparticle or nanotechnology or nanoscale or nanosize or nanostructure or nanocrystal or nm or nanometre or ultrafine	B82Y
Wood	Wood or timber	B27K 3/12, B27K 3/22,
Polish	Preserve or polish or coat or treat or impregnate	B05D 7/06, B27K 3/16, B05D 7/08 CO9G 1/16
Acrylic	Acrylic or acrylate or polyacrylic or polyacrylate	C09D 133/00
Resin	Resin or lacquer	
Protect from sun	Photoprotective or photoprotection or ultraviolet or UV/UVA/UVB or light or sunlight or absorbing or absorption/absorbing or stabilizing or photostabilization or photostabilization or filter	Review of IPC results suggested that this feature, searched alone, did not return IPC symbols relevant to the client’s invention

hybrid search approach. Patent classification systems are designed to be independent of terminology and jargon (including terminology changes over time) and therefore provide a way of counteracting problems such as patent jargon (“patentese”), keyword obfuscation and language-associated challenges.

The various patent offices and organizations (e.g., the United States Patent and Trademark Office (USPTO), the European Patent Office (EPO), the Japan Patent Office (JPO), the World Intellectual Property Organization (WIPO)) have different classification systems, but these are often organized according to different hierarchies, such that the classification of a technical area or invention in one system does not map directly to another. Concordances are available to translate between the different patent classification systems, and some offices are working on ways to harmonize their systems, such as the Cooperative Patent Classification (CPC) system being developed by the USPTO and the EPO.

Because an International Patent Classification (IPC) symbol has been assigned to most published patent documents, regardless of what other classification systems were also used, this guide will focus exclusively on using IPC symbols and the associated tools and functionalities that have been developed to help users maximize the potential of the IPC system. Detailed guidance for using the IPC system is available from WIPO (see Annex D).

### 3.1 Use screening tools to find potentially relevant classification symbols: Mapping keywords to patent classification symbols

You can use initial keywords, terms from any hypothetical claims you have drafted, other searchable text, such as names of processes or chemical substances, and even a complete invention description, as inputs to find IPC symbols using tools available on the WIPO IPC Publication (see Annex D). You can use information about “parts” of the application, such as type and technical field of the invention (e.g., descriptions such as a “binder for non-porous materials” or “glue for closing wounds”), to search for corresponding classification symbols.

**IPCCAT.** One helpful tool for using the IPC system is IPCCAT, the International Patent Classification Categorization Assistant. IPCCAT is a text categorization tool that uses text inputs to provide IPC symbol predictions at class, subclass or main group levels. To use IPCCAT, type or paste text into a text window. For example, you could paste in the invention disclosure

text, or hypothetical claims you drafted, and get recommended classification symbols. IPCCAT can be accessed through the “Search” tab on the WIPO IPC Publication.

**STATS.** The STATS tool can provide IPC symbol predictions based on statistical analysis of the patent documents containing specified search terms. STATS can be accessed through the “Search” tab on the WIPO IPC Publication.

**Term search.** You can conduct simple term searches (a sequence of alphanumerical characters) and multiterm searches (a combination of simple terms separated by space characters) in the IPC system. You can search for terms using the “Search” tab in the WIPO IPC Publication, from where you can also access the STATS and IPCCAT tools in the “Advanced Search” menu. This tool recommends classification symbols in the IPC system based on the terms you enter.

By using these tools you can map keywords or concepts to IPC symbols. Also, if you enter a keyword or text that has been mapped to an IPC symbol, this symbol or keyword can be used for expanding your query. If the definition is displayed with the suggested symbol, you can benefit from using these tools even if you are unfamiliar with the IPC. This is especially true for the biomedical domain, since the availability of detailed domain ontologies leads to very precise suggestions for classification symbols. Unlike the WIPO Pearl and WIPO Translate functions, the IPCCAT term search and catchwords functions are not integrated into the PATENTSCOPE interface.

You need to review the results generated by using these tools to ascertain which suggestions are the most relevant to the client’s invention. The class and subclass symbols increase precision by allowing you to differentiate between the results obtained when you use common terms that are used in many different ways, and their synonyms or homonyms.

For example, thousands of postings for “pen or pens” can be reduced to hundreds by searching more precisely for “pens for writing” or “animal pens” to get class and subclass symbols that are more specific for each type of pen. The homonym “mouse” (which can signify an animal or a computer accessory) is a good example of the advantages of using patent classification as compared to keywords.

Be aware, however, that some searches may not return results that are relevant to the client’s search, as shown in Teaching Example 9, where the functional feature of “protect from the sun” did not return relevant results.



### **3.2 Find IPC symbols in patent documents you have identified before beginning the search**

If you have already identified patent documents that are relevant to the client's invention, you can use the IPC symbols from those documents to search the IPC system, to see what IPC symbols were assigned. You can see what aspects of the invention disclosed in the patent document are reflected in the different IPC symbols that were assigned.

#### **Helpful hint**

The IPC Cross-references Search tool available from WIPO can help you identify co-assigned symbols. Although co-assignment data could also be inferred empirically by reviewing multiple patents, that approach is not recommended.

### **3.3 Find and refine IPC symbols through keyword searching**

In a different approach, you could do a "quick and dirty" search using keywords in a database such as PATENTSCOPE and study the IPC symbols that were assigned to the patents obtained by the search.

### **3.4 Rank and test IPC symbols for relevance**

As noted above, most patent documents are assigned multiple patent classification symbols that are relevant to different aspects of the invention and related disclosures found in the document. Therefore, you should expect that multiple IPC symbols will be appropriate for the client's invention, and these symbols may be from different parts of the classification hierarchy, for example in different classes or even different sections of the IPC scheme. However, you should also review the IPC symbols retrieved by the method described above and rank them according to their relevance to the client's invention. You should be able to identify the symbols that are most representative of the technology, and you can re-test those symbols for their relevance.

### **3.5 Use cross-references and co-assignment data to find related IPC symbols and add these to your search**

Certain technology areas, or technical features, are consistently assigned a group of IPC symbols from different parts of the classification hierarchy. Co-assigned symbols may not have a hierarchical relationship, but they may be semantically related, or related through a function or component found in each. If cross-referenced or co-assigned IPC symbols appear to be relevant to the client's invention, you should add them to the collection of IPC symbols you will use in the FTO search.

### **3.6 Optional: Use patent classification information to find additional potential keywords**

Finally, patent classification systems can provide additional keywords that may be useful for query expansion. For example, the IPC main search page provides a link to an alphabetical list of common "catchwords" and the IPC symbols that are often assigned when these words are used. The IPC Cross-references Search also provides a

list of catchwords associated with cross-referenced IPC symbols. As noted above, this function can be especially helpful for biological, chemical or biomedical inventions, because detailed domain ontologies that lead to precise suggestions for classification symbols can also provide access to additional catchwords that can be used as keywords.

### Recap

**FTO searches are a balance between recall and precision.**

**Preparing a search requires deconstructing an invention – that is, separating out the individual features and parts from one another so that each can be searched separately. These features will include the components, steps and functions required to achieve a generic example of the invention.**

**Deconstructing an invention provides the basis for building a list of keywords and phrases.**

**The list of keywords and phrases can be expanded by:**

- looking for synonyms or equivalents for the terms used to describe the components and steps of an invention
- considering both the structural and functional aspects of components, steps and functional features
- broadening specific concepts into general concepts.

**Patent classification symbols combined with other search terms can be very effective in formulating an FTO search and can increase the precision of a search.**

## 4. Select database(s) to search

Good FTO searching involves selecting the database or databases that will best allow you to search your client's invention, in view of any geographical limitations, time frames, search functions, language requirements, family coverage, non-text features or the need to access technically useful patent records.

Free searching of hundreds of millions of published patent records is available on public patent databases including:

- PATENTSCOPE administered by WIPO
- Espacenet administered by the EPO
- DEPATISnet administered by the German Patent Office (DPMA)

- Google Patents administered by Google
- The Lens (formerly PatentLens) administered as a joint initiative with CAMBIA (an independent non-profit institute) and Queensland University of Technology.

You may have access to one or more proprietary patent databases as well. Each patent database has its strengths and weaknesses, as briefly mentioned below in the context of how to evaluate a database.

The patent databases mentioned above are built to support complex search functions and permit retrieval of relevant patent documents. Although most national or regional patent office registers also allow patent searching, the search functions are often limited. Patent office registers are an authentic source for searching and retrieving legal status data, while multinational patent databases are secondary sources that may not be accurate or up to date (see Module IV).

You need to make sure that the **geographical and temporal coverage** of a database matches the geographical focus of the search, goes back in time as far as you need, and provides up-to-date information. In particular, *confirm that a database has the desired coverage of a country of interest*. For example, major public patent databases such as PATENTSCOPE, Espacenet and DEPATISnet provide access to hundreds of millions of published patent documents, but not all national collections (especially of smaller developing countries) are available or complete in these databases. For temporal coverage, you need a database that has patent documents going back at least 20 years, preferably more, and is regularly updated.

The patent database should have **search functions** that include the ability to:

- search published applications as well as granted patents
- selectively search patent parts for keywords and phrases (e.g., title, abstract, claims, full text)
- search for associated information, especially bibliographic information such as the patent owner
- search non-text features (if any).

If you need to **search in multiple languages** (other than English, accepted as the default language), the patent database(s) needs to allow searching in the desired language, or offer **translation** of search terms or documents, or provide translating interfaces to support searching for documents in other languages. You may want to retrieve **family information**, in order to track worldwide patenting activity related to an original disclosure. You may also wish to consider other

enhancements such as integrated analysis tools or integrated sequence searching.

You will want access to **technically useful patent records** such as:

- electronically searchable full-text patents and associated material (e.g., sequence listings, large tables)
- patent records that allow determination of legal status
- patent records with links to prosecution history or post-grant proceedings, assignment documents, renewal fee records and the like.

You should be able to retrieve any records that you access directly, or through links, in the format you need for a specific use, such as to populate charts for the FTO Search Report or to use in claim charts during FTO analysis.

Other considerations include availability, accessibility, cost, computer system compatibility, user-friendliness, search result format, completeness of patent records and the ability to organize and extract information from search results.

#### **Consider the value of searching multiple databases.**

All information scientists, whatever their specialization, will be familiar with the need to use multiple data sources to get a complete answer, and it is no different with patents: multiple resources can complement each other to meet most needs. When comparing patent information sources or databases you need to distinguish between searchable data (search fields) and retrievable data. Not all data that can be viewed or downloaded (retrieved) is searchable. Furthermore, not all databases enable you to separately search the claims – which *must* be searched for an FTO search – without searching the full text, including claims and description, and that may retrieve results that are not relevant. Some databases only allow keyword searching in the title and abstract and do not permit keyword searches in the full text, including claims and description.

## **5. Carrying out the FTO search: A hybrid strategy using keywords and patent classification symbols**

A hybrid strategy using a combination of keywords and patent classification symbols is a useful strategy for carrying out the FTO search. Using this method, you develop queries (search strings) with both types of search inputs, test them, refine them and repeat the search process until you determine that you have a suitable set of search results.

### **5.1 Overview: Search claims and abstracts first**

Your goal for the FTO search is to find potentially relevant patent documents. *The recommended strategy is to search the claims and abstracts first.* You may also search titles if you want. By including abstracts in the initial FTO search, you may find patent documents that use language matching your keywords in the abstract, even if the claims are written in “patentese” that does not match the keywords you are using.

Your ultimate goal is to determine whether these claims cover the client’s invention. If you find potentially relevant documents based on keyword matching in the abstract at the FTO search stage, then you can use them to determine the scope of the claims during the FTO infringement analysis stage. However, if you omit abstracts from the FTO search, then you may miss the opportunity to determine a claim’s scope.

*At a later time, you may want to search full texts, but you should only consider that after you have either:*

- found some patent documents that are a close match, so you want to learn more about keywords that are used to describe a relevant technology area
- found few or no patent documents that are a close match, so you want to test your keywords by searching full texts to see if anyone else has ever used the same keywords and phrases you are using in your search.

### **5.2 Tools for designing keyword search strings**

There are well-known standard methods of developing strings to search patent databases. The key for FTO searching is to decide how narrow or how broad you want the search to be, and to fine-tune the search string to achieve the scope of search you want.

The mechanics of developing search strings and using database tools is taught in tutorials and guides prepared by WIPO, all of which are available online. Video tutorials available through the PATENTSCOPE main page and WIPO guides (see Annex D) provide detailed instructions for searching the WIPO PATENTSCOPE database and using tools to maximize your ability to find potentially relevant information.

### Search syntax: Boolean and other operators

Effective use of Boolean operators, proximity operators and truncation operators is very important to determine the width of the scope. Detailed guidance for structuring searches and understanding search syntax is provided with the PATENTSCOPE database through the “Help” tab.

Briefly, Boolean operators can be used to narrow or broaden the scope:

- Use AND if you want to narrow the scope. All of the words connected by AND will have to be present in a search result.
  - For example, in the teaching example of the invention for making compound XYZ discussed above, a search string (X AND Y AND XY AND Z AND XYZ) would be a *narrow* search that would only find a patent document that claimed some variation on mixing X and Y to make XY, and adding Z to obtain end product XYZ.
- Use OR if you want to broaden the scope. Any one of the words connected by OR will have to be present in a search result.
  - For example, in the teaching example of the invention for making compound XYZ discussed above, a search string (X OR Y OR XY OR Z OR XYZ) would be a *broad* search that would find patent documents that claimed at least one of the components of the invention. Thus, if only compound X was patented, this search strategy should find relevant patent documents that claim compound X.

**Truncation** allows you to *broaden* your search by searching for the “root” of a word to find all its different endings. Truncation uses wildcard symbols for each specific database. Common truncation symbols are the asterisk (\*) or exclamation point (!), but you should always check to find which symbol is used by a specific database. Truncation allows you to search for all of these terms with one simple search strategy. **Stemming** allows you to find similar forms of a word by removing the inflectional endings, but does not necessarily find the root of a keyword (e.g., stemming for “go” would find “going” or “goes” or “gone” but would not find “went”).

### Further expand keywords and phrases: WIPO Pearl to find consistent use of terms and combat obfuscation

WIPO Pearl is a tool described as a “multilingual terminology portal [that] gives access to scientific and technical terms derived from patent documents” that “helps promote accurate and consistent use of terms across different languages” (see Annex D). You can use either the linguistic search or concept map mode. In the concept map mode, you can see the associative relation between two concepts and the generic or partitive relation between two concepts. WIPO Pearl can be used during the phase of developing keywords, and later during the phase of developing search strings. WIPO Pearl is also available in PATENTSCOPE, integrated into the “Tools” tab.

### Helpful hint

In some cases, it may be appropriate to use other operators such as NOT or ANDNOT. Use these only if you have determined that certain subject matter should be excluded. These operators should be used very carefully.

### Helpful hint

Consider making copies of the search results and then ranking or sorting the identical contents of each copy using different criteria. This will provide a good overview of trends in the search results.

### 5.3 Develop a search string: Query creation

#### Initial broad search string

Design an initial broad search string that includes keywords and key phrases for all of the essential features, as you developed them in the deconstruction step, combined with all of the IPC symbols you have identified so far.

The search string should be composed of a *comprehensive keyword string combined with a comprehensive IPC symbol set*. The keyword string should include keywords and key phrases for all of the essential features of the client's invention, connected by OR, *combined with* IPC symbols you have identified so far. The keyword string may include other operators such as proximity operators for words in key phrases, or wildcards to find different forms of the keywords. The IPC symbol set should include all the IPC symbols you have identified so far, including broad symbols at the class level only, and narrow symbols that include the subclass or subclass/group level.

#### Format options for initial search string

Initially you may want to formulate a single search string, for example to use in the "Advanced Search" interface for PATENTSCOPE. Another option found in some patent databases allows you to build searches by populating fields in a form, such as the "Field Combination" search interface for PATENTSCOPE. An advantage of entering search terms into form fields is that you only have to use minimal syntax, and the complete search string is automatically generated by the database with proper syntax. You can recover this search string and use it to modify and refine the search.

### 5.4 Carry out initial search and initial review

Run the initial search string and retrieve the search results. You can save the query and results in the database environment (e.g., in your WIPO account for PATENTSCOPE searches), or export them in a suitable format to store and manipulate on your computer. It is important to know what you can do with the search results in the patent database environment, and what you can do better in a local environment.

In the patent database, you can save a query and search results, change parameters and re-run the query, using different ranking or sorting tools on the same set of results. Learn what other tools for manipulating search result information are available in the database

you are using. For example, PATENTSCOPE has integrated some graphics and data analysis functions that may be useful for finding patterns and trends. On the other hand, some types of data analysis may be easier – or may only be available – in a local environment, such as exporting search results into Word tables or Excel spreadsheets (or into another spreadsheet program).

At this stage, you will want to review the search results to see how well the initial comprehensive search performed.

#### Sort and rank initial search results

The initial search may have returned a large number of results, especially if you searched in "all offices" (all countries). Therefore, you will probably want to sort or rank the search results according to various criteria to help you review them.

You can use one or more of the following ways to reorganize the search results to find useful information.

- **Default ranking.** Some databases such as PATENTSCOPE assign a rank to the search results, based on algorithms that establish which documents are the most relevant given your search terms, parameters and filters. Each patent's rank is a measure of how well this patent matches your search parameters, and is not an indicator of the quality or importance of the document. The top-ranked results probably matched more of the search terms in your query.
- **Chronological ranking.** See how the search results are distributed over time. For example, you may want to see if there are a lot of current patents that indicate inventive activity in the relevant technology areas. PATENTSCOPE also allows you to sort and rank search results chronologically according to date of filing or date of publication. For this function, you can remain in PATENTSCOPE, change the "Sort by" setting on the search results, re-run the query and save the new results. (Note that PATENTSCOPE has some integrated graphics capability as well.)
- **IPC symbol matches.** See which classification symbols returned more, or fewer, results.
- **Keyword matches.** See which keywords returned more, or fewer, results.
- **Sort by country.** The first results should be from the countries where the client has firm plans to use the invention. This allows you to separate the high-priority country-specific results from the rest of the results, especially if the client does not have firm plans to operate in any major markets. By separating countries, you can also see which countries are active in technology areas related to the invention.

- **Patent families.** You may have retrieved multiple documents that are members of the same patent family. If your database has an integrated patent family function (e.g., International Patent Documentation (INPADOC) in Espacenet, or Patent Cooperation Treaty (PCT) patent families in PATENTSCOPE), you can do a preliminary cleanup of the search results by sorting documents into patent families. This can highlight certain patent families that may become significant for your later searches. Alternatively, it may show you a patent family where keywords or IPC symbols return too many false positives, and you should consider how to modify search terms to avoid retrieving this family.

### Initial review of search results

Review the search results, especially if you did any sorting. Look at trends and associations. Consider the interplay between “broad net” features such as patent classification categories that may help catch related inventions where technical features are described differently, and “fine-grained sieves” such as keywords that will find inventions that use similar terminology.

If the search returned a large number of results (especially if you searched all offices), then there is an opportunity to focus the search.

If the search returned very few results, then you should try to expand the search. Expanded keyword searching, such as going from structure to include function (see the acrivastine and aspirin example above), may help you to “cast a broad net.”

## 5.5 Modifications

After the initial review, consider whether you need to modify the search. Your goal is to retrieve potentially relevant patent documents and avoid retrieving irrelevant patent documents. Modify and test your search to determine whether you can improve the results.

### Initial modification: Feature-specific searching

If the search returned a large number of results, you may want to determine which features or concepts of the invention returned more results.

Because you previously identified essential features and relevant IPC symbols during the deconstruction stage, you should be able to write separate search queries for each essential feature, using expanded keyword language that expresses the feature as a concept. For continuity with the initial search, break up the

initial search string into a collection of narrower search queries, each of which is directed to a single essential feature. By treating an essential feature as a concept, this approach will give you an idea of how important each concept is to the breadth of the FTO search.

An illustration of breaking a comprehensive search query into separate queries for each feature (concept) is shown in Teaching Example 10 using the wood polish invention.

### Reformulating the query: Query reduction and query expansion

The initial query can be reformulated to select, remove or expand terms for improved retrieval. Query reformulation methods can be based on keywords (syntactic) to match terminology, or meaning (semantic) to match mutual information, and are often carried out as an iterative process to keep improving the quality of the search results. Reformulation methods include:

- **Query reduction (QR).** The query is reduced to a subset of terms that are perceived as having higher relevance. QR methods can also use terms from IPC definitions.
- **Query expansion (QE).** Representative terms other than the ones already in the query are added to expand the scope of the query. This method often uses synonyms or hyponyms to expand the query with terms having similar meanings.
- **Hybrid (QE & QR).** Irrelevant terms are removed from the query (QR) and relevant terms are added (QE) to form a new query.

### Broaden the search scope: Expanded keywords, additional IPC symbols

The initial comprehensive search string is used as a test search to find areas of the search that can then be carefully expanded to obtain higher recall in those areas.

**Query building.** PATENTSCOPE shows a query tree icon when the results are retrieved. If you click on the icon, the system parses your last query again, decomposes your query into subclauses and executes each subclause individually, letting you know the associated number of intermediate results. You can optimize and expand your query by looking at the results for the subclauses and putting them together appropriately.

**Focus on expanded keywords.** You can broaden the scope of the search by focusing on the expanded keywords, i.e., the broader keywords produced by structural or functional expansion, or from expansion from a specific concept to a general concept. These expanded

### Teaching Example 10: Feature-specific searches

For the example of the wood polish invention discussed above, here are examples of feature-specific search strings and the number of search results (hits) each search returned.

Feature	Query	Offices	Hits
Zinc oxide	CL:(ZnO OR "zinc oxide") OR IC:(C09C1/04 OR C01G9/02)	All	71,978
Wood polish	((CL:(preserve OR treat OR protect OR coat) OR IC:(C09G1/16)) AND AB:(wood OR wooden OR timber)) AND IC:(B27K3/12 OR B27K322 OR B05D7/06 OR B27K3/16 OR B05D7/08)	All	108
Acrylate	CL:(acrylic OR acrylate OR polyacrylic OR polyacrylate) AND IC:(C09D133/00)	All	7,160
Ultraviolet	CL:((UV OR light OR ultraviolet OR sunlight) AND (protect OR screen OR absor* OR stabili* OR filter))	All	241,120

keywords broaden the search to find potentially relevant patent documents based on shared structural characteristics, functional characteristics or technological concepts. The broadened search may be able to find potentially relevant patent documents based on underlying meaning, instead of matching terminology (keyword searching) or IPC symbol assignments.

**Additional IPC symbols.** As you incorporate expanded keywords, search for additional IPC symbols that may be associated with these terms.

### **Expand the search to other languages: Cross-Lingual Information Retrieval (CLIR) in PATENTSCOPE**

If your client plans to operate in multiple countries with multiple official languages, then you need to search in more than one language. You need a way to perform the same search in other languages and accurately find relevant subject matter in patent documents in other languages.

The PATENTSCOPE interface is currently available for searching in multiple major languages including Chinese, English, French, German, Japanese, Korean, Russian and Spanish. Furthermore, in many cases a patent document that has already been translated into a major language may be retrieved by a search in that major language. However, the document may have been found using IPC symbol matches and not necessarily based on accurate keyword matches.

**CLIR** is an extension available in the PATENTSCOPE database. Your search query in one language will be translated into several other languages, where the terms used in other languages are based on statistical analysis of patent documents and terminologies to find what terms are used to refer to the same thing in each of these languages. Having a search query in several languages should enhance the quality of search results from the databases containing data in those languages.

By entering a term or a phrase in one language, it is possible to retrieve relevant patent documents in any of the languages supported by CLIR. A significant advantage of the CLIR extension is that you can select the level of precision you want for your query by selecting the “Expansion mode” as either “supervised” or “automatic.”

Using query translation can *narrow* the search by accurately searching within the target language. This is quicker than translating all documents in the data set and then retrieving the relevant documents from them. In some cases, cross-lingual retrieval is useful

when you do not speak other languages. Using the cross-lingual system, your query will be translated and relevant documents provided. You can then examine these documents to find useful images or diagrams in patents that did not have a corresponding patent in your original search language. Therefore, using query translation and then retrieval can be more beneficial than document translation followed by retrieval.

### **Translation support: WIPO Translate and other machine translation options**

To overcome the cross-lingual retrieval issues, PATENTSCOPE offers access to machine translation systems. On the search page, you can access WIPO Translate through the “Translate” tab. WIPO Translate is the WIPO internal translation tool, described as “a powerful tool trained specifically to translate patent texts,” which can be used by cutting and pasting text from any patent document into the text box and selecting the desired language pair. The effectiveness of WIPO Translate comes from it being trained specifically on patent documents, so it can focus on terms appropriate for the technical domain and use specific vocabulary according to the technical field of a document, especially a patent.

PATENTSCOPE also provides integrated access to multiple free machine translation options. You can translate search results using the “Machine translation” button on the search results page. You can also translate any document you retrieve from the search results using the “Machine translation” tab on the document. PATENTSCOPE offers access to WIPO Translate, Google Translate, Bing/Microsoft Translate and Baidu Translate. Use of WIPO Translate is recommended because the translation will take into account specific vocabulary according to the technical field of the translated patent.

## **5.6 Searching “WHERE” and “WHEN” based on the client’s plans for using the invention: Adding geographical limits and time frames to search**

### **Geographical limits**

Because patent rights are only in force in the country that granted the patent, you will want to consider where the client plans to use the invention. The question of geographical limits may affect the number and breadth of search results you get. Geographical limits may also affect your choice of databases to search, as you need to make sure there is sufficient coverage for the countries of interest.



Using information you gathered for the Summary Report in Module II, identify the countries where the client plans to use the invention. You must choose databases with high-quality patent records from at least those countries. You may take a selective or an inclusive approach as to whether to limit the number of countries to search, or whether to search many countries and sort the search results later. Consider whether the client has a very definite, fixed list of countries they are interested in, or whether they want to search *potential* markets as well, in case they want to expand. Consider whether to include at least one major market such as the United States of America, the European Union, China or Japan or a similar market, for at least two reasons:

- The invention may eventually be used in those markets even if the client did not originally intend it;
- If the search is limited to a few countries with less comprehensive IP office records, then searching in a major market would increase the potential for better coverage of relevant patent families.

#### **Adding date restrictions to the FTO search**

You have the option to include a date restriction in the FTO search, based on the client's expected time frame to make and use the invention in each country. You may want to search only for patents that have not expired by the time the client plans to be using the invention, and avoid retrieving expired patents that would represent out-of-date technology. You may want to include patent applications, to search for potential future patent rights that would still have some patent term when the client plans to be using the invention.

For utility patents, most countries have adopted a patent term of 20 years from the effective filing date of the first application, regardless of how long after the filing date the patent was issued. However, you should remember that some countries have procedures to extend the effective length of a patent term to compensate the patent owner for various types of official delay, such as patent office delays for any technology, or delays due to seeking regulatory approval for certain technology fields. Therefore, the simplest and safest approach to date restrictions is to search for patent documents that were filed no more than 25 years before the client plans to begin using the invention, representing 20 years for a normal patent term and a generous estimate of possible extensions.

This cutoff date should also take into account any database entries that have an ambiguous effective filing date. When the search results are returned, you may want to sort documents based on their predicted expiration date, calculated from their effective filing date.

For example, a client plans to start selling the product of the invention in early 2020. If you are only interested in patents that are still in force by 2020, or could potentially be in force by 2020, you can use the generous 25-year cutoff to search for patent documents with an effective filing date of January 1, 2000 or later.

If the client is planning to operate in more than one country, they should have communicated the time frame when they plan to begin operating in each country. If the client has different start dates in

#### **Helpful hint**

Carry out one search limited to the target countries the inventor identified, and then carry out a *separate* search of a potential major market, using the search strategy. Then carry out a complete FTO analysis of the search results from the first search that was limited to target countries. The search results from the second search can be held in reserve, in case you or the client decide there is a reason to review and analyze those results as well.

#### **Helpful hint**

Remember that other instruments such as utility models, petty patents or mini-patents have shorter patent terms, so you will need to adjust the applicable time limits or carry out a separate search for these documents.

different countries, you can apply the date restriction separately for each country, if you are using a database that allows that level of control. Otherwise, apply the cutoff date that corresponds to the earliest start date in any country.

Different activities may trigger different date restrictions. For example, a client plans to begin manufacturing in one country in 2018, and plans to start selling the manufactured product in other countries in 2020. If you are searching for methods and products separately, the “method” search would have a cutoff date of 1998 (or earlier), but the “product” search would have a cutoff date of 2000 (or earlier).

On the other hand, the inventor might be interested in knowing about historical patenting activity in the technical field of the invention, including what was claimed in expired patents, and therefore you might choose *not* to include a date restriction for the search. In that case, you may want to sort the search results and identify the expired patents as a group that does not require FTO analysis, but could provide useful background information on technological or business trends.

The safest approach is to omit date restrictions, or only include them in the final cycle of your search queries. This is advisable because you want to have *all* possible patent documents in your search results, and date restrictions might introduce factors that affect other search parameters if you limit by date early on. It is preferable to carry out a broad search and then sort the search results to prioritize patents that are in force or might be in force when the client plans to use the invention. Expired patents can be separated from the search results, as can abandoned patent applications, and these can be identified as documents that will not require FTO analysis.

## 5.7 Searching non-text features using specialist databases or functions

Your client’s invention may use chemical compounds, proteins or nucleotide sequences as non-text functions that require specialized searching. For inventions involving chemistry, biology or biotechnology, you can search for the following non-text features using search tools included in free databases:

- Chemical structure (scaffold), chemical name, IUPAC (International Union of Pure and Applied Chemistry) name, CAS (Chemical Abstracts Service) number and so on can be searched using the chemical search functions available in the PATENTSCOPE database.
- Protein or nucleotide sequences can be searched

in the “Patent” division of the GenBank database using BLAST (Basic Local Alignment Search Tool) or by using the Lens patent sequence search tool.

In addition to the free databases listed above, proprietary patent databases, and other non-patent databases, may support chemical or sequence searching. Other specialist databases may be useful for finding information such as *all* the terms that have been used to identify a protein or gene, or an enzyme classification number, or names for a polymer configuration.

### Searching for chemical compounds

You will need to use specialized techniques for precise and high retrieval of certain chemical subject matter inventions that are claimed in patents. Common chemical names can be used as keywords, although a complete search should include deconstruction and query expansion, as mentioned below, to find references using different nomenclature or broader chemical structures.

**Search tools available in PATENTSCOPE.** The free PATENTSCOPE patent database supports chemical searching using different inputs such as IUPAC names, international non-propriety names (INN), other common chemical names, trade names and chemical structure, although some advanced chemical searching functionality requires a free WIPO account. The chemical structure search functionality allows you to upload a chemical structure to PATENTSCOPE and search for scaffolds, which can retrieve documents that disclose compounds with the same core structure. Guidance in using chemical compound search functions in PATENTSCOPE can be found in the PATENTSCOPE User Guide (see Annex D).

**Scaffold search.** Uploading your exact chemical structure in PATENTSCOPE and searching for scaffolds will give you an overview of compounds with the same core structure. The “Search for scaffold” button will enlarge your search as the compound will be searched more generally, taking into consideration only the first part of the Inch Key. The scaffold is a basic skeleton of a molecule to which further groups and moieties are attached. Different options to enter the chemical compound in your search are available: by trivial name, commercial name, IUPAC name, CAS name, INN, InChI, InChIkeys or SMILES (simplified molecular-input line-entry system). You can submit your query directly or check the structure using the “show in” editor. This will process the input data to convert the compound name, INN, InChI or SMILES into the corresponding structure. Although this makes

searching for chemistry structure less challenging, you still cannot search directly for “Markush” structures in PATENTSCOPE.

**Challenge: variable nomenclature.** One of the challenges in searching for chemical compounds is the wide variability in nomenclature in the chemical arts. Your search may be directed to a species, multiple species or a genus.

For example, a simple chemical compound can be represented in many ways in chemistry. Ethanol can be described as: ethanol, ethyl alcohol, grain alcohol, pure alcohol, hydroxyethane, drinking alcohol, ethyl hydrate or absolute alcohol. Ethanol could be also depicted structurally as any of the following:

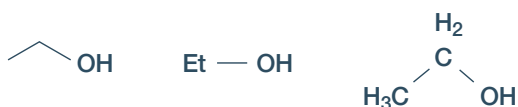

**Challenge: compound disclosed in a generic Markush structure.** The chemical compound(s) of interest may be disclosed in a Markush structure. Markush structures are important for an FTO determination because they allow inventors to claim large numbers of structurally related compounds (most of which may not actually have been synthesized) that are expected to produce the desired activity, thus preventing competitors from marketing compounds that are closely related to the inventor’s primary choice. Of course, if these compounds can be shown to lack the claimed activity, this may invalidate the patent in whole or in part.

**Deconstructing an invention directed to a chemical compound: start with expansion.** Searching for the exact chemical compound alone is not sufficient for an FTO search because the search must also retrieve patents with broad claims that cover (read on) or encompass the chemical compound. Therefore, you have to expand the search from specific concepts to generic concepts. You will need to deconstruct or disassemble the chemical compound – and the invention comprising the compound – to carry out effective searches. Depending on your database access, some of these deconstruction functions can be automated using tools or functionalities that generate alternative ways of representing or naming a chemical compound, or functionalities that generate catchwords that are commonly used with a chemical compound.

In Teaching Example 11, aspirin expands functionally into the general class of analgesics and structurally into hydrobenzoic acids. Similarly, acrivastine expands functionally into the general class of antihistamines and structurally into the general class of alkylamines. As discussed previously, these are not just synonyms.

**Option: Deconstruction map.** Deconstruction for inventions directed to a chemical compound requires determining a generic chemical structure, a specific scaffold structure that can be used in a scaffold search (e.g., in WIPO PATENTSCOPE) and finding synonyms for the chemical compound (such as trade names and alternate chemical names). It also requires deconstructing/disassembling the entire invention.

### Terminology hint

A **Markush** structure has effectively come to mean any form of generic chemical structure, usually involving variable groups, designated R1, R2 and so on, that are defined separately from the main structure diagram, and which encompasses a set of individual specific structures.

### Helpful hint

If you use a patent database that does not have sequence searching integrated into its functionality, then you may have to carry out a *separate* search for protein or nucleotide sequences. For example, although PATENTSCOPE provides lists of protein or nucleotide sequences in published patent applications, direct sequence searching is not available at this time. Some proprietary databases may offer integrated sequence searching.

Teaching Example 12 gives an example of a deconstruction map for diclofenac as a gel formulation. The chemical compound diclofenac is shown as its specific scaffold structure<sup>8</sup> and expanded as a generic chemical structure, trade names and chemical names. The invention comprising diclofenac as a gel formulation is identified as a “chemical product” and the entire invention is deconstructed by expanding the description into generic terms for gel, including colloids, and its use as a topical product.

### Searching for protein or nucleotide sequences

If the client’s invention involves a protein with an identified sequence, or an RNA or DNA molecule with an identified sequence, then you can search for these non-text features using sequence searching. Free searching for sequences disclosed in patent documents can be performed by accessing the “Patent” division of the GenBank database using the BLAST program that finds regions of similarity in biological sequences, available from the United States National Library of Medicine’s National Center for Biotechnology Information (NLM NCBI). To search for nucleotide sequences, access the BLAST page on the NCBI website, select “Nucleotide BLAST,” paste in the nucleotide sequence (or identifier such as an accession number) and select the “Patent sequences (pat)” database. To search for protein sequences, access the BLAST page, select “Protein BLAST,” paste in the protein sequence (or identifier such as an accession number) and select the “Patented protein sequences (pat)” database. The BLAST interface allows you to select other criteria such as organism of origin, allows you to exclude certain properties and allows you to select the stringency of the search using optimization tools, different versions of the BLAST algorithm and specific inclusion and cutoff settings. Guides and support for using BLAST are provided through the “Help” tab on the BLAST page.

Another free patent sequence search tool described as having an interface similar to the BLAST search interface is available from the Lens using the Patent Sequence (PatSeq) database originally developed by CAMBIA. This search tool is distinguished by the feature that allows you to carry out a focused search for *patent sequences that are claimed* in patents and patent applications. Presently, accessing BLAST through the NLM NCBI will search for disclosures throughout a patent document, and you will have to review the results to differentiate between sequences that are simply disclosed in the specification and sequences that are recited in the claims.

**Deconstructing an invention with protein or nucleotide sequences.** For nucleotide or amino acid sequences, you have to determine how you want to enter the client’s sequence (e.g., does it have any variable or non-naturally occurring residues?). Separately, you should use any associated text descriptors such as protein name, gene name or vector name as keywords for query expansion and text-based searching.

**Sequence searching has a built-in mechanism for deconstruction** because you can set the stringency of the BLAST search. You should use a low-stringency setting such as “more dissimilar” or “somewhat dissimilar” to find patent documents that disclose sequences that are similar to but not exactly the same as the client’s sequence. You will return more results, but you can clean up the data by selecting the documents with matches in the claims. Then, during the FTO analysis stage, construe the claim to determine how much similarity is required, and compare the client’s sequence with the construed claim, in a step that may require using the BLAST algorithm to align the sequences and calculate similarity or “homology” of the sequences (see Module IV, section 4.4, “Infringement analysis when claims include non-text features”).

### Recap

**The databases you choose to search must:**

- cover the geographical regions in which your client wishes to use their invention
- contain high-quality patent records
- contain both historical (dating back at least 20 years) and up-to-date information
- offer appropriate search functions.

**Consider searching multiple databases.**

**Carry out the search in a logical order, search claims and abstracts first.**

**Begin your search using a broad search string:**

- If you retrieve a large number of results, you can focus your search.
- If you retrieve few results, you should expand your search.

**Review your initial search results to help you modify your search and improve its efficacy and efficiency; you may choose to make modifications based on:**

- features of the invention
- terms used for searching
- scope of the search
- language.

### Teaching Example 11: Deconstructing a combination drug

The client has a combination drug comprising acrivastine (an antihistamine allergy blocker) and aspirin to combat allergic symptoms. To deconstruct the invention, you have to take aspirin and acrivastine to a generic level, both structurally and functionally.

Aspirin	Acrivastine
<ul style="list-style-type: none"> <li>- Functional expansion: analgesic</li> <li>- Structural expansion: hydrobenzoic acid</li> </ul>	<ul style="list-style-type: none"> <li>- Functional expansion: antihistamine/anti-allergy</li> <li>- Structural expansion: alkylamine</li> </ul>

### Teaching Example 12: Deconstruction map of diclofenac as a gel formulation

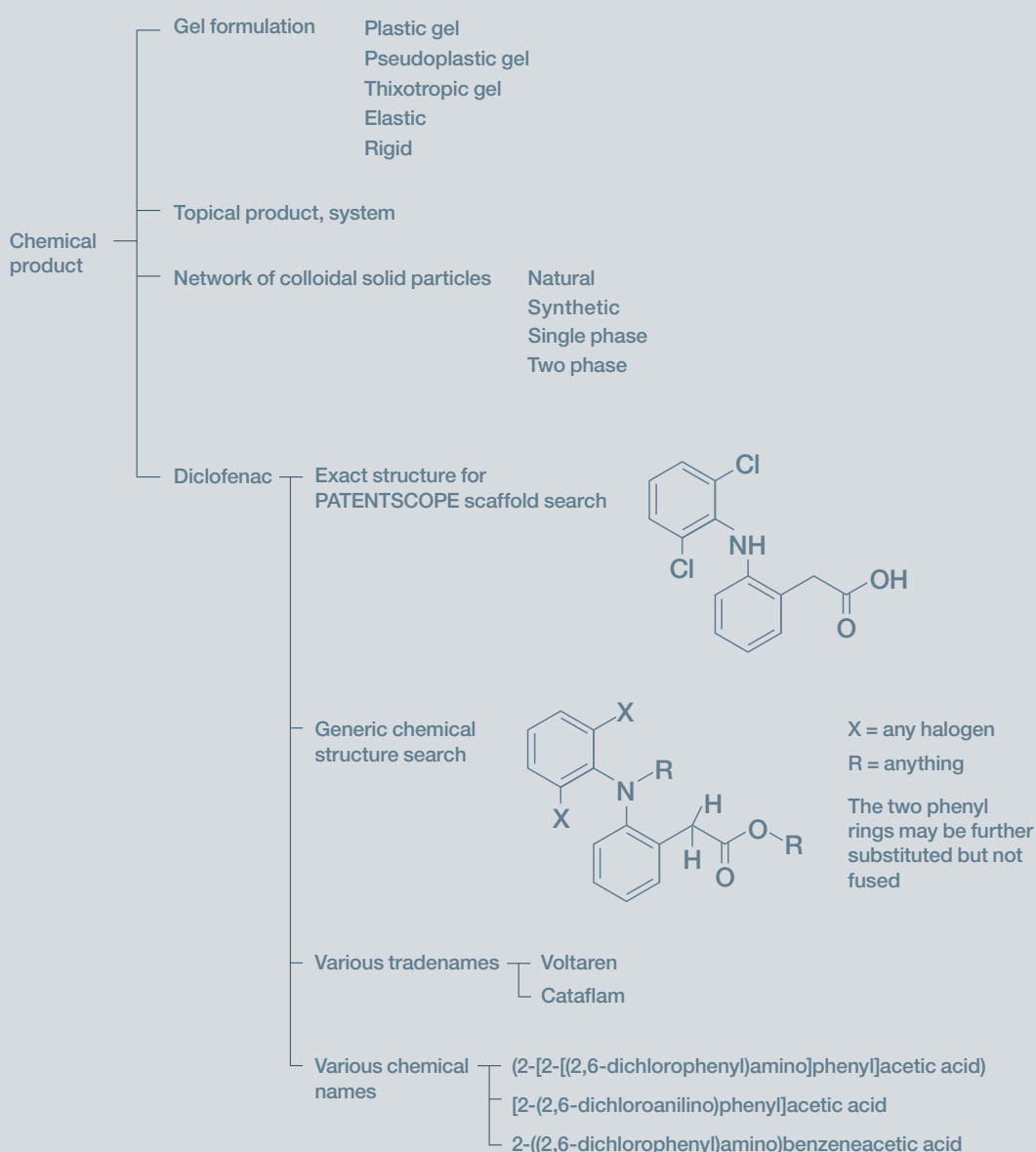

**Consider including a major market when limiting your search geographically; in this way you may find increased numbers of relevant patent families and also be able to assess potential implications of using an invention in that market, even if the client does not initially intend to do so.**

**To ensure that you find more potentially relevant patent documents to review, omit date restrictions or use them only in the final cycle of searching.**

**Specialist databases or search functions are available for searching for patents related to chemical, biological or biotechnological inventions.**

### **5.8 FTO search as an iterative process: Review, refine, repeat... stop**

Continue to test search strings and review the results. Decide what further modifications may improve the recall of potentially relevant documents. Carry out an iterative process of searching, reviewing the search results, modifying the search query to refine it and repeating the cycle of search and review.

Use adaptive strategies, based on learning from the positive and negative aspects of previous search results, and adapting to that knowledge by modifying the search to get a different set of search results each time.

During intermediate stages of the search process, you will get a good idea of whether you are narrowing or broadening the scope. You should be able to detect if any of your modifications eliminated irrelevant patent documents. Careful review of the search results – possibly using the sorting and ranking techniques discussed above – is essential to determining whether the search is finding suitable results. At each step, consider how the whole search has proceeded thus far.

You will also need to decide when to stop searching. In some cases, you could stop after the initial search if it has returned a manageable number of results to review. If you did multiple rounds of searching using modified search strings, you can decide when modifications are no longer improving the quality of results and it is time to stop. The decision to stop may depend on the client's understanding of the importance of precision and recall, and the client's appetite for risk. It is important to explain that a search with greater recall has lower precision, and involves a greater investment of time and money, but may mean lower risk because the search is designed to find a large number of results, even if only a few are relevant.

### **5.9 Collect the final set of search results to use for preparing the Search Report**

Finally, you will have determined that you have a suitable set of search results and will end the search. You may have multiple sets of queries and search results in your final collection. These different sets can reflect searches for different features of the invention, or searches for specific countries or time frames.

Your records should include saved queries and the search results they generated, along with any notes and comments about strategic choices, modifications to search queries and insights from sorting and ranking of search results.

## **6. The Search Report**

When you run searches, save each query with the associated set of search results, either stored on a database-associated server (e.g., as a PATENTSCOPE stored search) or exported as a local download (e.g., as a Word table or Excel spreadsheet).

### **6.1 Format the search results**

During the search stage, you selected search fields and terms that you wanted in the search results. For the Search Report, prepare a table of search results. You need to set the data export function of the patent database to populate a table or spreadsheet as shown below.

The table should display at least the following information:

- **Patent or publication number**, with link to electronic copy if possible
- **Country or patent office** that granted the patent or published the application
- **Title** of patent or application
- **Owner(s)/Applicant(s)/Assignee(s)** listed in the database
- **Inventor(s)**
- **Application number and filing date**
- **Date of patent grant** or publication date for an application
- **Priority**, including earliest priority application and earliest priority date
- **Estimated expiration date** of the patent, or estimated potential expiration date for a published application.

If possible, include information relevant to the search, such as:

- (Optional) All **IPC symbols** assigned to the patent or application.
- **Matches between IPC symbols** in the query with IPC symbols assigned to the patent or application.
- **Matches between keywords and phrases** in the query with text in the patent or application title, abstract or claims.

The results should be formatted in a way that allows you to access the text of the claims or abstract that matched your search terms. You can include the matching text in the table, or provide a link to a separate entry that displays the matched text outside the table.

You could include additional information (if the database supplies this information) such as:

- **Patent family**, especially INPADOC and PCT patent families.
- **Reported legal status**. Include this only if the database provides a legal status report. Otherwise, do not determine the legal status at this time.
- **Ranking or relevance**. You may choose to rank search results according to some measure such as the degree to which claims disclose features of the invention. For example, as H (high potential relevance), M (medium potential relevance) or L (low potential relevance). Some databases, such as WIPO PATENTSCOPE, provide rankings in a set of search results, based on calculated relevance to the search query that was used.
- **Other relevant parameters** the client may have requested, such as patent owners or inventors.

### Clean up the search results

When you select search results that you want to examine further, you need to consider whether the results need data cleanup. One of the biggest concerns may be de-duplication (unless the database has a built-in system for doing this). If you are storing the search results as spreadsheets in Excel, then the Excel de-duplication facility may be sufficient. You can use other Excel functions such as text-to-columns, filters and pivot tables to clean up or improve visualization of results.

### Sort the search results

When search results are exported into a table, some type of sorting will happen. If nothing else, they may be sorted by patent number. You should decide if you want to sort the results according to parameters such as country (country code), expiration date or ranking.

### Consider graphics, charts, maps, visual tools

Consider whether any aspects of the search results lend themselves to being expressed using images, charts, patent “maps” or other visual tools to communicate the results.

## 6.2 Search Report

The Search Report should include at least the information listed below. This document will be very data-oriented and will have

### Helpful hint

You can also decide whether you want to manage separate sets of search results, or download all the search results into the same document. For example, you may want to have separate sets of search results from different search strings of different scope. If you carried out separate searches for different essential features of the invention, you may want to keep the search results for each feature-specific search. (However, you should also prepare a master list of all the search results.)

little discussion and analysis. The Search Report can be generated using information such as search strings and results that have been stored electronically. Therefore, no template for the Search Report is provided.

### Search overview

This part of the report details the objective, background, search criteria, assumptions and databases searched. The objective and the background of the FTO search can provide insight into the technical problem of the invention, but do not need to go beyond the discussion in the Summary Report of Module II. The search criteria and assumptions should detail the spatial and temporal limits to be applied and any specifics that your client wants incorporated into the search. Mention the databases used to retrieve the datasets here.

### Search strategy

This part should describe the various search strings used, listing the keywords and IPC symbols. Report the number of patent documents that were returned for each query. Mention strategic decisions about reformulating the query, using expanded keywords, or similar.

If you ranked the patent documents when formatting your search results, you can include information about the criteria you used for ranking patent documents, such as H (high potential relevance), M (medium potential relevance) or L (low potential relevance, may be a background document).

### Search results

Decide how you want to present the results. You may want to arrange the search results into subsets based on the client's concerns, such as:

- **Results grouped by country.** Results can be further sorted within the subset (e.g., based on predicted expiration date or relevance).
- **Results grouped by feature.** Identify patent documents with claims that disclose just one or two of the essential invention features, as these may indicate patents that cover underlying technology. Likewise, identify patent documents with claims that appear to match most or all of the essential features.
- **Results grouped by search query.** For example, show results of narrow searches in a separate table from results of broader searches.

Breaking up the results into subsets may allow you to bring certain information to the client's attention. For example, you could show that search results from one

target country returned many results that you ranked as H or M, while another country that was considered to be an attractive market returned few results. This will only provide a preliminary indication – the result of the FTO analysis will have much greater influence on what countries the client chooses.

However, if you break up the results into subsets, you should have a master list of all the patent documents in the Search Report.

### Conclusions: Minimal

The Search Report is an intermediate step on the way to FTO analysis. The most effective aspect of the Search Report may be how you choose to arrange the search results. You have an opportunity to comment on any surprising results, or how patent documents ranked, but you do not need to include a lengthy discussion.

### Recap

#### Store your results for each search query.

#### Identify the final set of search results you want to use for preparing your Search Report:

- **Export your results into a table or spreadsheet**
- **Clean up your search results**
- **Sort your search results, for example by patent number, or country, expiration date, ranking, etc.**

#### Your Search Report will:

- **Provide an overview of the search**
- **Describe the search strategy**
- **Present the search results**
- **Draw minimal conclusions.**



# Module IV

## FTO analysis: Reading claims and legal status information

### 1. Introduction

This module demonstrates how to use the tools of FTO analysis to evaluate the patent documents you identified in the FTO search, in order to determine whether there are any existing or potential patent rights that could potentially impact your client's planned use of the invention.

Infringement of a patent involves practicing what is covered by the patent claim(s), in the country where the patent was granted, during the patent term when the patent is in force, without the authorization of the patent owner. FTO analysis therefore involves determining what is covered by a patent claim, followed by comparing the claim with the client's invention to determine whether the claim could be found to cover the invention, and then concluding by determining where and when the claim might be enforceable.

#### Learning points

Once you have completed this module, you should understand how to:

- Review FTO search results and organize results for FTO analysis.
- Carry out informal infringement analysis, including claim construction and comparison of construed claims with the client's invention using claim charts.
- Carry out legal status determination.
- Make determinations based on your FTO analysis.
- Prepare a Final Report to communicate your findings to the client.

FTO analysis is a **multistep process** that includes two separate analyses:

- **Infringement analysis** to:
  - interpret (construe) the meaning and scope of claims in patent documents
  - compare each interpreted (construed) claim with the client’s invention
  - determine whether every claim limitation (element) might be found in the client’s invention
  - evaluate whether the claim could be interpreted to cover (read on) the client’s invention.
- **Legal status determination** to establish whether, where and when a patent may be enforceable.

This guide teaches a method of informal FTO analysis to evaluate patent documents from multiple jurisdictions and generate technical findings that will be communicated in a Final Report to the client. The informal FTO analysis method taught here differs from the methods used in certain other approaches to FTO determination. Furthermore, the technical Final Report differs from certain other kinds of products based on FTO determination.

FTO analysis is often carried out by a licensed professional such as an attorney or a non-attorney patent professional. A legal professional such as an IP attorney may carry out FTO analysis of the results of an FTO search and render a legal opinion on FTO issues, based on applying the rules and standards of the jurisdiction(s) in which they are licensed to practice.

The FTO opinion reaches a legal conclusion and in some cases provides legal advice. A licensed non-attorney patent professional such as a patent agent would be expected to limit any FTO analysis to the jurisdiction(s) in which they are licensed.

In contrast, this guide teaches you the use of FTO tools to apply general principles of FTO analysis to generate technical findings, which are communicated in a Final Report. The guide teaches general principles of infringement analysis to analyze patent documents from multiple jurisdictions. It also teaches general rules for determining the legal status of a patent document, regardless of jurisdiction.

These general principles of infringement analysis include “canons of claim construction” and guidance for comparing a construed claim with an invention based on a high-level synthesis of accepted approaches in multiple jurisdictions. Although this guide points out jurisdictional differences, you are only expected to apply the general principles taught in this guide. If you choose to apply knowledge of jurisdiction-specific rules and standards for infringement analysis in your

analysis of a patent document, you should indicate this in your notes and Final Report.

The guide teaches you how to determine the legal status of a patent document according to widely implemented rules relating to priority, effective filing date and patent term found in instruments such as the Patent Cooperation Treaty (PCT) and the Agreement on Trade-Related Aspects of Intellectual Property Rights (TRIPS). You are expected to apply these general rules, and are encouraged to explore jurisdiction-specific rules that may have an effect on patent term and legal status. However, you are not expected to make an authoritative statement about the legal status of a patent document.

You must inform your client that your Final Report communicates *technical findings* based on your informal FTO analysis of potentially relevant patent documents, and *is not* a legal opinion. These technical findings are not intended to be a substitute for a formal FTO analysis prepared by a qualified professional, in particular, a licensed attorney. The client is responsible for evaluating the technical findings from your informal FTO analysis and deciding how to proceed.

## 2. Organization of FTO analysis

As a first step, you should review the FTO Search Report and decide how you want to organize the FTO analysis process for efficiency and usefulness. In addition to listing potentially relevant patent documents, the FTO Search Report may contain information such as search term matching, country of grant, legal status, expected expiration date, rankings, and links to patent family information. This information can be useful for organizing your approach to FTO analysis, as well as for determining claim scope and legal status.

### 2.1 Choose the order in which you practice infringement analysis and legal status determination

Usually, infringement analysis is carried out first and legal status is determined second. You can choose a different order, depending on the circumstances. If the FTO search returned a significant number of results, then you may want to determine legal status first, in order to identify enforceable patents that you can prioritize for analysis.

You also need to decide which patent documents to analyze. You must decide whether you want to analyze

pending patent applications, with the understanding that pending claims in patent applications can only be interpreted as disclosing potential future patent rights. You may choose not to analyze patents that have expired at the end of their full term. For example, a database that includes legal status indicators should allow you to find patent documents that are marked as “in force” or “pending” and then decide whether to also analyze the documents marked as expired, canceled, withdrawn, abandoned, invalidated, lapsed, disclaimed or otherwise unenforceable.

### Helpful hint

Remember that patent databases are secondary sources of legal status information, so consider whether you need to confirm patent legal status using authentic data from a national or regional patent register, before deciding whether to analyze a patent document.

## 2.2 Decide whether to sort and prioritize search results

If the FTO search returned only a few results, then it may be efficient to analyze the search results in the order they occur in the FTO Search Report.

However, if the FTO search returned a large number of results, then you may want to prioritize certain results to analyze first, in order to address issues of greater concern and identify potentially serious problems sooner. Options for sorting and prioritizing search results include:

- **Prioritize by country.** You may want to sort the search results by country, because any patent rights (or potential patent rights) are limited to the country of grant. The client may be more interested in certain countries and want the analysis for those countries performed first, to determine whether to even consider other countries.
- **Prioritize by assigned ranking.** Search results may have been ranked by relevance in the Search Report, for example by the WIPO PATENTSCOPE database, or your own evaluation. If the search results were ranked, then you may wish to prioritize the documents rated as more relevant.
- **Prioritize by feature.** You may want to focus on results relating to a particular feature or set of features first, before looking at the rest of the results. A certain feature may be of the greatest concern for the client, due to potential coverage by patent rights. A related option is to prioritize patent documents owned by parties of interest that the client has identified, such as potential competitors or firms that have a dominant position in a technology area.
- **Prioritize by predicted expiration date.** Your search results may include a predicted patent term or expiration date. The client may only need an analysis of patents that could be in force when they plan to start using the invention at a specific future date.

## 3. Background to FTO analysis: Claims in patent documents

It is critical to understand the functions served by claims and the formats that claims can take. The structure and function of claims are important for infringement analysis to determine their scope of coverage. The scope of claim coverage is critical to determining whether a claim may cover (read on) your client’s invention and concluding whether the claim is found in a patent that may present a potential FTO issue for your client. Some background describing the various

types of claims is presented below, prior to discussing how claims are interpreted and analyzed.

### 3.1 Claim structure

Patent claims determine the legal scope of protection associated with the patent. Most patents contain more than one claim, and it is possible to infringe more than one claim from a single patent. National (and sometimes regional) laws determine the format of patent claims, but certain structural aspects are universal or extremely common. Each claim in a patent should take the form of a single sentence with a full stop (period) at the end of the claim. Furthermore, *a claim contains the following three components, in order:*

- a preamble
- a transition
- one or more limitations.

The limitations form the main body of the claim and define the limits of the claim elements setting forth the features of the invention. Parts of a claim and their functions are described below.

#### Parts of a claim: Preamble

Every claim begins with a preamble. The preamble is a (typically short) phrase that identifies the type of claim and may also provide an indication as to the substantive subject matter of the claim. The preamble will often (but not always) indicate whether the claim is independent (e.g., by stating “a process” or “a product” and not referencing any previous claim) or dependent (e.g., by stating “the process of claim x” or “the product of claim x” or “a process *according to* claim x”). In some instances a dependent claim may contain a reference to a previous claim in the main body or limitations, rather than in the preamble.

In some cases the preamble will provide further details about the claimed subject matter, such as an intended use of a product or an intended output of a method. In some jurisdictions, such statements may be considered limitations – that is, they may be considered elements of the claimed invention that limit the scope of the claims and are required for a finding of infringement, just as much as any of the limitations that follow the preamble and form the body of the claim. In the United States of America a preamble is interpreted in the context of the entire claim and is treated as a claim limitation if it “gives life and meaning” to the claim. For example, the preamble might be considered a limitation if it recites an intended use for a claimed device and the intended use is strictly the result of the novel structure of the device.

#### Parts of a claim: Transition

After the preamble, but before the list of limitations, every claim will contain a transition, which may be a word or phrase. In some jurisdictions, a transition is referred to as a “link” or “linking phrase.” The three most common transitions are **comprising**, **consisting of** and **consisting essentially of**. Local laws may provide guidance on interpreting these transitions, but the following explanation is fairly universally accepted for the three most common transitions.

The transition **comprising** is used where a claim is intended to cover products or processes that contain *at least* all of the limitations recited in the claim, and may (or may not) contain additional elements or process steps. Claims that use the comprising transition are referred to as “**open**” or “**open-ended**” claims because there are no limitations on *additional* elements beyond those listed in the claim.

The transition **consisting of** is used where a claim is intended to cover products or methods that contain *exactly* those limitations recited in the claim, but nothing else. Consisting of is a more restrictive transition than comprising, and is much less commonly used. Claims that use the consisting of transition are referred to as “**closed**” claims.

The transition **consisting essentially of** is a compromise term that is used where a claim is intended to cover products or methods that contain only those limitations recited in the claim, but may also contain any non-essential elements that do not substantially change the nature or fundamental characteristics of the product or process. For example, “[a] pharmaceutical composition *consisting essentially of* active agent X” would cover compositions that contain active agent X as well as non-essential components that do not change the fundamental characteristics of the composition, such as an inert carrier or filler.

Teaching Example 13 shows how preamble and transition are used in a claim.

#### Parts of a claim: Limitations

In a patent claim, a “claim limitation” or “claim element” is a part of the claim that defines or describes a feature of the invention. In the claim, there should be a claim limitation (element) or a set of claim limitations (elements) corresponding to each feature of the invention, where the claim limitations set the limits and define the scope of the feature. Each limitation included in a claim *narrows* the scope of the claim.

As discussed in Module I, if each and every limitation (element) of a patent claim is found in a product or process, then the claim is said to cover (read on) that product or process, and using the product or process would practice the patented invention and infringe the claim. Because it is the claim limitations that set limits and define scope, this relationship is known as the “all-limitations rule” or “all-elements rule” and can be expressed as follows:

For a potentially infringing product or process to infringe a claim, it must satisfy *every* limitation that is in the claim, and if *any* limitation of a claim is *not* present in a potentially infringing product or process, then there is no infringement of the claim.

Illustrations are provided in Teaching Example 14.

### 3.2 Types of claims: Classification by scope, function and/or subject matter

#### Independent and dependent claims

A claim can be an independent claim or a dependent claim, each of which has a different scope and function.

An **independent claim** is a claim that does not refer to any other claim. It contains everything necessary to define an invention. That is, an independent claim contains a preamble, a transition and claim limitations that define the “essential features” of the invention. The scope of an independent claim is determined solely from the limitations that are present and recited in the claim. Thus, it is not necessary or proper to look at any other claims when determining the scope of an independent claim.

In contrast, a **dependent claim** makes reference to another claim or several other claims. By referencing another claim, the dependent claim assumes all of the limitations that are present in the referenced claim, and then *adds* one or more additional limitation(s) that are not present in the referenced claim. The requirement of having one or more additional limitation(s) is important because it distinguishes the dependent claim from the referenced claim.

Since each limitation in a claim narrows the scope of the claim, in all cases a dependent claim is narrower in scope than the claim from which it depends. A dependent claim may reference an independent claim, or it may reference another dependent claim. A “multiple dependent claim” can reference more than one independent or dependent claim.

Teaching Example 15 provides more detail.

The distinction between dependent and independent claims is important for an FTO analysis because a dependent claim is always narrower in scope than the independent claim from which it depends (in Teaching Example 15, claims 2 and 3 are narrower in scope than claim 1). Therefore, *FTO analysis should always start*

#### Terminology hint

The terms **claim limitation** and **claim element** are often used almost interchangeably, and are used that way in this guide to refer to claim language that recites a feature of the claimed invention. However, these terms sometimes have different meanings in other jurisdictions.

### Teaching Example 13: Preamble and transition

Consider the following claims:

- **A table comprising** a flat surface and four legs attached to the flat surface.

“A table” is the preamble, which identifies the type of claim and general technical area (e.g., furniture). The transition “comprising” indicates the claim is **open-ended**, such that the table must have a flat surface and four attached legs, and *it can have additional features not recited in the claim*, such as a drawer attached to the flat surface, or an additional leg.

- **A table consisting of** a flat surface and four legs attached to the flat surface.

“A table” is the preamble, which identifies the type of claim and general technical area. The transition “consisting of” indicates that the claim is **closed**. Under normal rules of claim construction, the claim would *only* cover a table with a flat surface and four attached legs, and would *not* cover a table with a flat surface and four attached legs and a drawer attached to the surface.

### Teaching Example 14: Claim limitations

Consider the following two claims:

- Claim 1: A table comprising a flat surface and four legs attached to the flat surface.
- Claim 2: A table comprising a flat surface, four legs attached to the flat surface and a drawer attached to the flat surface.

Claim 1 contains two limitations: four legs and a flat surface. For a table to infringe claim 1, it need only satisfy two limitations: it must have a flat surface and four legs.

Claim 2 contains three limitations: four legs, a flat surface and a drawer. For a table to infringe claim 2, it must satisfy three limitations: it must have a flat surface and four legs and a drawer.

Both claims describe tables, but claim 2 is narrower than claim 1, because a smaller number of products in the universe of tables will have all three limitations and infringe claim 2. That is, tables *with* drawers or *without* drawers may infringe claim 1, but only tables *with* drawers may infringe claim 2, meaning that claim 1 is broader in scope than claim 2.

### Teaching Example 15: Independent and dependent claims

The following example illustrates independent and dependent claims, and a chain of dependency:

- Claim 1: A table comprising a flat surface and four legs attached to the flat surface.
- Claim 2: The table of claim 1, further comprising a drawer attached to the flat surface.
- Claim 3: The table of claim 2, wherein the flat surface is made of wood.

In the above sequence of claims, *claim 1 is independent* because it does not reference any other claims.

*Claim 2 is dependent* on claim 1, such that all of the limitations of claim 1 are read into claim 2, and the claim contains an additional limitation not present in claim 1, so that the scope of claim 2 is narrower than claim 1.

*Claim 3 is dependent* on claim 2, so the limitations of both claims 1 and 2 are imported into claim 3, along with the additional limitation provided in the text of claim 3. Thus, a table of claim 3 must have a flat surface with four legs and a drawer attached to the surface, and the flat surface must be made of wood.

with the independent claims of a patent document. If FTO analysis finds that a potentially infringing product or process does not appear to infringe an independent claim, then you may conclude that there is no infringement of any of the dependent claims, as these are narrower than the independent claim.

The reverse, however, is not always true. If you find that a potentially infringing product or process does not infringe one dependent claim in a patent, you must still carry out an analysis for other dependent claims to determine whether the product or process infringes any of the other dependent claims, as well as the independent claim from which they depend.

Furthermore, in view of the principle of claim differentiation, which provides that two claims are presumed to have different scopes, it may be helpful to review dependent claims even where the independent claim is found not to be infringed. In some cases, recognizing the limitations present in a dependent claim helps to interpret the independent claim.

#### Claims based on the type of invention: Product and process claims

Another way to classify claims focuses on the type of invention being patented. The claim is classified based on the type or category of invention being claimed, such as a “new product, process or apparatus or any new use thereof” as defined by the European Patent Office (EPO), or a “new and useful process, machine, manufacture, or composition of matter” as defined by the United States Patent and Trademark Office (USPTO), or categories defined by other patent offices. Different kinds of rights are granted by claims to the various types of inventions.

A **product claim** (also known as a composition claim, composition of matter claim, device claim or apparatus claim) is directed to a physical product. This type of claim includes claims to devices, compositions and articles of manufacture. Product claims are characterized by having limitations that recite physical elements (e.g., components) of an invention.

A **process claim** (also known as a method claim) is characterized by limitations that recite a sequence of steps. Process claims include claims to methods of making, methods of using, methods of carrying out various activities, and methods of diagnosing or treating a disease.

**Product-by-process (PBP) claims** are a type of product claim with process limitations, where the PBP claim is actually directed to a product, but the claim recites one

or more process steps that are used to make the product. Other types of claims are allowed in some jurisdictions, especially those that limit the ability to claim medical or surgical treatment. (Some jurisdictions prohibit claims, and the grant of patent rights, to any medical or surgical treatment, while others only prohibit claims directed to the medical treatment of humans.) These include the “**second medical use claim**” that recites a new or further medical use of a known therapeutic substance, taking the format “substance X for use in treatment of Y,” where X is a known substance and Y is a disease or condition. Some jurisdictions allow the “**Swiss-style claim**” that takes the format “[u]se of a compound in the manufacture of a medicament for treating a disease or condition” or similar language.

Some jurisdictions allow “**use**” or “**method of use**” **claims** that recite a new use of a known composition, device or process, where the claims are understood to be directed to the new use and not the previously known composition, device or process. The EPO allows “use” claims while the USPTO does not.

#### The kinds of rights granted by the various types of claims

The claim classifications discussed above are important because they determine the kinds of rights granted by the claim.

*A product claim provides rights for the patent owner to exclude others from making, using, selling, offering to sell, or importing the claimed product, regardless of how the product is made or used.* For example, a product claim to a new pharmaceutical active agent will be infringed if a third party does any of the following:

- makes the active agent by *any* method, whether or not the method is disclosed in the patent
- uses or encourages the use of the active agent in any process
- sells or offers to sell the active agent
- imports the active agent.

Specific limits on these and similar acts may vary from jurisdiction to jurisdiction.

In contrast, *a process (method) claim provides rights for the patent owner to exclude others from making, using or selling the claimed process (method).* For example, a patent that covers a process that is not limited to the use of specific components, might cover a third party’s use of the patented process to make a novel end product using starting materials that were not disclosed in the patent. However, if a pharmaceutical company has a patent to a method for making a pharmaceutical

active agent, and a third party finds a *different* method for making that pharmaceutical active agent, the patent for the method will probably not grant the patent owner the right to stop the third party from making the same active agent by the different method, or selling the active agent made by the different method.

Regarding PBP claims, you will need to review local law and court decisions to determine whether such claims are treated as protecting the product made by any process or only by the process recited in the claims.

#### **Deviations or ambiguities in claim structure and type**

The patent offices of some countries do not conduct substantive examination of patent applications. In these countries, the claims do not undergo review and therefore format errors are not identified or corrected. Under these circumstances, granted patents may exhibit significant deviations from the conventions described above. For example, non-standard transitional phrases (or no transitional phrase) may be used, which may present a problem for FTO analysis if you cannot clearly determine whether the claim is open or closed, or somewhere between open and closed.

## **4. Infringement analysis: Claim construction and comparison of construed claims with the client's invention**

Infringement analysis is a two-step process. The first step is claim construction, which is a determination of the scope of the claim or claims of interest. The second step involves comparison of the construed claim with the potentially infringing product or process, to determine whether the construed claim could cover (read on) the product or process. Each claim in a patent document that was identified as potentially relevant in the FTO search stage should undergo claim construction and comparison.

### **4.1 Claim construction**

The scope of protection of the patent document is determined wholly by the language of the claims, but may involve interpretation of that language by looking beyond the claims to other parts of the patent such as the specification or drawings. Interpretation may look beyond the patent to other sources such as comments made by the patentee during prosecution of the patent application.

#### **Claim construction proceeds limitation by limitation, where each limitation of the claim is analyzed separately**

The goal of claim construction is to interpret the language and limitations of a claim, so that when the claim is compared with a potentially infringing product or process (in this case, your client's invention), the presence or absence of each claim limitation in the product can be determined.

Teaching Example 16 presents the claims in a hypothetical patent identified in an FTO search, with three claims directed to a fertilizer composition. These hypothetical claims are discussed below to explain how the scope and meaning of the claims is determined using various sources of information, and to illustrate the principles of using such sources to interpret claims.

#### **Sources of information for claim construction**

When construing claims, there are two types of sources of information – those that *must* be considered, and those that are *optional*. Sources that must be considered (i.e., mandatory sources of information) are generally limited to anything that has been stated directly by the patentee, whether in the patent document itself or during prosecution. Optional sources of information include extrinsic evidence such as dictionaries and prior art and the like.

#### **Mandatory sources of information for claim construction**

**The claim language.** The first and most important source of mandatory information in claim construction is the literal wording of the claim. Every word that is present in a claim is important, and will have some effect on the scope of the claim.

Many jurisdictions operate under a “**plain meaning**” rule whereby a word in a claim will be afforded its plain and normal meaning in the context in which it is found, unless there is some reason to alter that meaning. The plain and normal meaning of a word is not, however, a dictionary definition, but is rather typically determined from the perspective of a person who has ordinary skill in the art to which the claim is directed.

In the fertilizer claim, for example, the limitation of “30–40% of a nitrogen-containing component” is, on first reading, very straightforward. Any composition that contains a nitrogen-containing component of any variety within the range of 30–40% would satisfy



### Teaching Example 16: Claim construction for product and method claims

In this teaching example, your client is a manufacturer and wholesaler of fertilizers. Your client wishes to manufacture and sell a new fertilizer, including directly or indirectly exporting the fertilizer regionally or internationally. Your client has developed packaging that instructs the end-user on the proper use of the fertilizer, which includes applying the fertilizer under certain conditions, in certain amounts and for the growth of certain plants.

The FTO search identified at least one potentially relevant patent in a country of interest to your client. The patent contains independent claims directed to a composition intended for use as a fertilizer (claim 1), a method for making a composition for use as a fertilizer (claim 2), and a method of using the fertilizer composition of claim 1 (claim 3). The claims recite the following:

1. A composition for use as a fertilizer comprising:  
30–40% of a nitrogen-containing component,  
30–40% of a phosphorus-containing component and 30–40% of a potassium-containing component.
2. A method for making a composition for use as a fertilizer, the method comprising combining 30–40% of a nitrogen-containing component, 30–40% of a phosphorus-containing component and 30–40% of a potassium-containing component to form a homogeneous composition.
3. A method for using the composition of claim 1, the method comprising applying the composition to a plant or to soil in an amount suitable to enhance the growth of the plant.

### Terminology hint

The process of determining the scope of protection offered by one or more claims in a patent document is referred to as **claim construction** or **claim interpretation**. These terms are used interchangeably in this guide.

this limitation. Questions may arise, however, whether the required 30–40% is a weight percentage or a volume percentage, or whether such percentages indicate the final product or the ingredients used to make the final product, or other ambiguities with the limitation.

**The patent specification.** Claim construction does not stop at the literal language of the claims. A second source of mandatory information that you must consider is the patent specification. Recall that a patent consists of a set of claims as well as a specification, the latter containing a detailed and summarized description of the invention, an abstract and potentially one or more drawings. Your FTO analysis must involve review of the specification, at least for the reasons described below.

It is an axiom in patent law that the patentee can be their own lexicographer. This means that a patentee, when drafting a patent application, can clarify a term and can even decide to use a non-conventional definition for a term, provided that such clarification and/or deviation is clearly stated in the specification. Thus, interpretation of a term in a claim may involve checking the specification to determine if the plain meaning of the term is applicable, or whether the meaning of the term has been modified or clarified by the patentee. Such checking of the specification is particularly important for relative terms. If the term is not defined or clarified in the specification, interpretation of the term may require consulting other sources of information such as dictionaries. For example, a claim may recite the step of “applying heat to a solution” in order to bring about a chemical transformation, but the term “heat” is a relative term that is likely to have been defined or clarified in the specification.

In the example of the fertilizer claim, the specification may provide a list of nitrogen-containing compounds, and may state that the list is “exemplary” or that it provides “non-limiting examples” of suitable compounds. In such a case, it is likely that the claim would not be limited to covering the compounds in the list provided in the specification (unless other factors alter this conclusion, such as estoppel, described below). Other known compounds that contain nitrogen, or even compounds that are discovered after the filing or priority date of the granted patent, might be covered by the claim.

There is a caveat for consulting the specification during claim construction. In some jurisdictions and in some situations, it is inappropriate to consult the specification for the purpose of importing limitations into a claim. An “imported limitation” is one that is not intended by the applicant to be part of the claims, and goes beyond merely clarifying a term used in a claim.

In our fertilizer claim example, the specification might, for example, provide a number of representative fertilizer examples that have 30–40% by *weight* of a nitrogen-containing compound. Because the literal claim language is not specific as to how the 30–40% nitrogen value is calculated, it would not necessarily be proper to infer that the claims only cover compositions with 30–40% by weight of a nitrogen-containing compound. The claim would likely be construed

to also include compositions containing 30–40% by *volume* (unless other factors alter this conclusion). On the other hand, when the claims do not specify limits with sufficient precision, they may be liable to attack for indefiniteness.

**File history and prosecution estoppel.** A further source of mandatory information that you should consult for construing the claims is the record of correspondence between the patent applicant and the granting patent office. This is referred to as the “prosecution history” or the “file history” for the granted patent.

In applying for a patent, an applicant may be required to interact with the patent office. This is often the case when the local patent office undertakes substantive examination of the patent application (or applies the results of search and examination conducted by another patent office), and issues an initial rejection of one or more of the claims of the patent application. The applicant has an opportunity to respond to the rejection with arguments and/or claim amendments, in the hope of addressing the examiner’s concerns and overcoming the rejection. The patent office may respond to such submissions by maintaining the rejection, withdrawing the rejection, making a new rejection, or granting the application as argued or amended. The applicant can respond to these actions, and the process continues until the applicant and patent office reach consensus and a patent is granted, or the application is abandoned, either because the applicant and patent office cannot reach consensus, or because the applicant chooses to abandon the application for other reasons.

Arguments and amendments submitted by the applicant may touch on the substance of the claims, particularly where the applicant attempts to overcome a rejection over a prior art reference. In some jurisdictions, this may lead to “**prosecution estoppel**” where the argument or amendment becomes binding on the patentee in future proceedings that are unrelated to the original exchange between the patentee and the patent office. Prosecution estoppel is based on the principle that a patentee cannot make one argument to the patent office in order to obtain a granted patent but then ignore, abandon or alter that argument later when trying to assert the patent in infringement proceedings.

As an example of prosecution estoppel, consider the claim above to a composition intended for use as a fertilizer (claim 1). During substantive examination, the patent office rejects this claim over a prior art reference that discloses a fertilizer composition containing

29% nitrogen, 35% phosphorus, and 36% potassium. The examiner, in making the rejection, states that 29% nitrogen is very close to (and therefore essentially covered by) the applicant’s claimed range of 30–40% nitrogen. In response to the rejection, the applicant argues that 29% nitrogen as recited in the prior art reference falls outside of the claimed range of 30–40% for nitrogen, and that the aforementioned range should be interpreted strictly and literally in this instance. The argument is convincing and the patent examiner allows the application to become a granted patent. In an FTO analysis of this claim, you should account for the patentee’s argument, because it would be unlikely, in view of such an argument existing in the file history, that a court would go against this and loosely construe the range in this claim during an infringement proceeding.

Thus, in some countries, file histories are important, not least because amendments and arguments made by the patent applicant may be considered admissions by the patentee and may be given as much weight in claim construction as any other statement by the applicant, such as statements in the originally filed specification and claims.

The importance of the file history as a mandatory source of information for claim construction will vary by jurisdiction and for a variety of reasons. In jurisdictions where there is no substantive examination, there is not likely to be any direct prosecution history to review because the local patent office will have granted the patent without receiving any statements by the patentee. Furthermore, although prosecution histories are public records, not all jurisdictions currently make prosecution histories readily accessible for public inspection.

**Litigation records.** A final source of information that warrants mandatory review is any litigation history of the patent. The patent may have been the subject of prior litigation involving infringement by a third party. Such litigation is likely to involve claim construction by the court or tribunal, as well as arguments in support of or in opposition to such claim construction by the patentee. As with prosecution estoppel, statements made by the patentee during litigation can provide an estoppel against the patentee making contradictory arguments in future cases, and you should consider them in claim construction for an FTO analysis.

Although the literal language of the claims is always the first stop for information in claim construction, review of the other sources mentioned above is referred to as mandatory. This is because, even where it appears

from the words of the claim that there is no ambiguity, any of the above sources may contain contradictory information that cannot properly be ignored without sufficient justification. In contrast, the optional sources of information described in the following paragraphs *can* properly be ignored if there is no ambiguity among the mandatory sources.

### Optional sources of information for claim construction

You may also consult a variety of non-mandatory sources of information when preparing an FTO analysis. These sources are **extrinsic evidence** and should be consulted only when the mandatory sources described above are insufficient to provide a clear answer for construction of a limitation in a claim.

Dictionaries, including technical dictionaries, are a common source of extrinsic evidence for the definition of common words and technical terms. Dictionaries can sometimes provide different definitions, so use such sources sparingly. Determining which dictionary is the “right” dictionary to provide a definition is a subjective process.

Another source of extrinsic evidence is prior art references, and in very extreme cases, references that are not prior art (i.e., references with a publication date later than the priority date of the patent being construed). Such references may be useful if they provide information that is known to a person of skill in the art, and may be called upon to determine common usage or meaning for terms of art. Similarly, you may seek expert opinion in order to further interpret terms in a claim, provided that the FTO analysis is clear that such expert opinion is the source of such information.

Prior art identified during the FTO search may also help to interpret the claims. In our fertilizer example, perhaps the FTO search identified a decades-old patent document that provides a composition used as a fertilizer and that contains 30% by *volume* (but only 25% by weight) of a nitrogen-containing compound. In this example, assuming that the prior art was known during prosecution, it could be argued that the claims *must* be interpreted as “30–40% by weight” in order to distinguish them from the prior art. By any other interpretation, such as if the 30–40% value were interpreted more broadly to encompass volume as well as weight percentages, the claim would be invalid over the prior art.

The sources of information described above combine to provide a body of resources that you can use in claim construction, with the goal of determining the

most likely interpretation of the language of the claims. After such determination, the FTO analysis can progress to a comparison of the claim with the client’s invention.

### Caveats to claim construction

Certain additional considerations may be relevant to claim construction for FTO analysis.

In some jurisdictions, and depending on relevant case law and/or statute, the **doctrine of equivalents** must be considered. This doctrine provides that a claim term may be interpreted to include obvious variations or equivalents of the term itself, even if such variations are not explicitly included in the corresponding specification of the patent. For example, where a claim mentions a zipper as a fastener, the doctrine of equivalents might allow a claim interpretation that covers buttons as an equivalent embodiment to zippers, even if buttons are not explicitly mentioned in the specification. The doctrine may extend a claim term only as far as equivalents that were known at the time a patent was filed, or may extend it to include later-developed equivalent embodiments. In some jurisdictions, rather than applying to specific claim elements individually, the doctrine is applied to the claim as a whole. The doctrine of equivalents may be codified, or may rely partially or entirely on court decisions. This guide does not teach a separate method to search for or analyze patent documents under the doctrine of equivalents, and a sufficiently broad search strategy should help you find and recognize patent documents that recite equivalents.

It is also important to remember that, in some jurisdictions, the claims of a granted patent may not have been substantively examined. This means that the claims have not been “approved” as clear or unambiguous by a qualified patent examiner, and there may be minor or substantial ambiguities present in the claims. Unexamined patent claims are not necessarily presumptively valid, and this presents a challenge when conducting an FTO analysis. An FTO analysis should indicate whether the reviewed patent claims were subjected to substantive examination by a patent office. Where a review is conducted on a patent granted by a non-examining patent office, you should consider that related foreign patents or applications may exist and that such related patents or applications may have been subjected to a substantive examination by a foreign national or regional patent office. Such searches/examinations may be helpful in claim construction of an unexamined patent.

## 4.2 Comparison of construed claims with the client's invention

After claim construction, you will carry out a comparison step to determine whether the claim could cover your client's invention. In the comparison step, the construed claim as a *whole* is compared with the invention as a *whole*. As mentioned previously, the "all-elements" or "all-limitations" rule for determining infringement requires demonstrating that *all* of the limitations of a claim are present in a potentially infringing product or process. You will need to compare each claim limitation with your client's invention, using your construction of the scope and meaning of that limitation to determine whether there is a "corresponding element" or "corresponding structure" in your client's invention that would satisfy that limitation. If you find a corresponding element or corresponding structure for each limitation, such that the client's invention satisfies all of the limitations of the claim, then the claim would "cover" ("read on") the product or process.

### Use claim charts to organize information during claim construction and comparison

Because the "all-elements" or "all-limitations" rule for determining infringement requires demonstration that *all* of the limitations of a claim are present in a potentially infringing product or process, *it helps to represent a claim using a table (often called a "claim chart") with each of the limitations in the claim given a unique row in the table.* A claim chart is a visual aid that will help you organize the claim construction and comparison process. With a claim chart you can break up the claim, enter notes on claim construction and try to align claim elements with possible corresponding elements in the client's invention. The claim chart may also show "gaps" where no corresponding structure is found in the client's invention, so that claim limitation is not satisfied. That is, the claim chart can be helpful in showing when some of the required elements are missing. Likewise, the claim chart can show "gaps" where elements of the client's invention do not correspond to elements in the claim. A template/worksheet for making claim charts is provided at Annex C.2.

After you compare a claim limitation with the proposed corresponding structure in your client's invention, you should make a determination as to whether that claim limitation is, or is not, satisfied by the proposed corresponding structure in your client's invention. Your final determination will be one of the following for each limitation: yes; probably yes; no; probably no; cannot

determine. The table should include an additional column to show this determination. You should keep detailed notes on how you reached each determination for each limitation. These notes can be included in the claim chart (possibly in a separate column) or kept separately. An optional, but recommended, feature is a "Conclusion" box at the bottom of the claim chart. A claim chart can be arranged and completed as shown in Figure 4.

Figure 4: Setting up and completing a claim chart

<b>Claim limitation</b>	<i>[Paste in the claim, word for word from the original. Break up the claim into preamble, transition and limitations. Each limitation is given a separate row. Limitations are typically, although not always, separated by semicolons.]</i>
<b>Claim construction</b>	<i>[This column allows you to enter notes and comments. These notes should help you understand the scope of the preamble, the transition and each claim limitation.]</i>
<b>Corresponding structure in client's invention</b>	<i>[Anything from the client's invention that might fall within the scope of what is recited in the corresponding part of the claim, in particular each claim limitation, is placed in this column. Include explanations if necessary.]</i>
<b>Limitation satisfied?</b>	<i>[Try to draw a conclusion (with explanatory notes if necessary) as to whether, or to what extent, the claim limitation is satisfied.]</i>
	Optional (recommended) conclusion section as to whether the claim could cover the client's invention.

### Claim construction and comparison for a product claim

Teaching Example 17 illustrates how to use a claim chart for documenting claim construction and the comparison step. It considers product claim 1 discussed earlier, directed to a composition for fertilizer.

Several points in Teaching Example 17 require further explanation.

Regarding *the preamble*, the analysis is complicated by the mention in the specification of other uses for the composition. It is possible that the mention of such other uses is sufficient to detach “fertilizer” from the composition, and the mere mention of fertilizer in the preamble would not be construed as a limitation. Alternatively it is possible that the non-fertilizer uses of the claimed composition have been disclaimed (i.e., the patentee is not claiming such uses) since only fertilizer is mentioned in the claim. In this example, since the client’s product is also used as a fertilizer, the FTO analysis need not expound further on the effect of the preamble.

Regarding *the nitrogen-containing compound*, the specification listed only one example of a suitable compound, and indicated that the example was non-limiting. The client’s product uses a nitrogen-containing compound that is different from the example provided in the patent. Nevertheless, it is likely that the single example in the specification will not be considered limiting, and that another well-known nitrogen-containing compound could be substituted and still be found to infringe the limitation. The amount of nitrogen-containing compound in the client’s product, at 35%, is clearly within the claimed range of 30–40%. It should be recognized, however, that it may be common practice in some jurisdictions to allow for some flexibility in claimed ranges, particularly where the claimed range was not amended during prosecution of the application and/or where the patent specification explicitly states that such ranges are exemplary or flexible. In the example, a court might find that the range 30–40% includes values that are slightly outside of the range (e.g., 29% or 29.5%) as well as all values within the range. It is important for the FTO review to discuss this possibility with reference to any relevant laws or judicial decisions in the jurisdiction.

Regarding *the phosphorus-containing compound*, the patentee stated during prosecution that the claim does not cover a composition containing 26% phosphorus, and amended the claim accordingly. The client’s product has 29% phosphorus, an amount that falls outside of the claimed range by a mere 1%. Claim construction for this specific term would be highly jurisdiction-dependent. Some jurisdictions consider that any claim amendment made for the purpose of excluding a prior art reference eliminates the benefit of loose interpretation of that range (i.e., the amended range will be interpreted with no flexibility). Other jurisdictions are less strict with such amendments, and may still afford a small buffer to the edges of the claimed range. Such jurisdictions might find that the 1% difference between the client’s invention and the lower end of the range is not significant (i.e., it is trivial) because the client amended the claim to avoid prior art with a much greater difference.

### **Claim construction and comparison for a process claim**

Teaching Example 18 shows claim construction and comparison for example claim 2, the method of making the fertilizer composition. The order of carrying out the process steps recited in a claim may be important, and patent specifications will often indicate whether this is the case for the specific invention.

In the case of process claims, it may be the case, due to the style and wording of a claim, that finding infringement would require looking at the actions of more than one actor. For example, a process claim might recite the following four steps: formulating a message, transmitting the message, receiving the message, and processing or displaying the received message. It may be that a single entity would never have reason to carry out all four of these steps, but that two entities (which may or may not be related) would carry out the steps in aggregate. The treatment of such claims will vary by jurisdiction. In some jurisdictions, a single entity must carry out every limitation of the claim in order for there to be a finding of infringement, whereas in other jurisdictions, the claim limitations can be split among entities provided that there is some connection between the activities or entities.

### **Claim construction and comparison for a method of use claim**

Teaching Example 19 illustrates a claim chart for construction and comparison of the method of use provided in example claim 3.

As discussed above for process claims, some inventions involve the actions of more than one actor, and the treatment of such claims will vary by jurisdiction. In this case, your client might not carry out the claimed method of using the fertilizer composition, since such actions are typically carried out by the end-user, such as a farmer who applies the fertilizer. Nevertheless, in some jurisdictions, the fact that your client has marketed the product with instructions for use is sufficient to amount to “inducing” infringement by a third party. You will need to consider the local laws on inducement of infringement in such cases.

## **4.3 Option: Carry out the comparison step before undertaking extensive claim construction**

As you review the FTO search results, you may notice that some of the potentially relevant documents have significant *differences* from the client’s invention,

Teaching Example 17: Using a claim chart to show claim construction and comparison for a product claim

Claim limitation	Claim construction	Corresponding structure in client's invention	Limitation satisfied?
A composition for use as a fertilizer	Preamble – is use as a “fertilizer” a claim limitation? Specification provides several alternative uses for the material.	Client's composition is used as fertilizer and for other purposes.	Yes
comprising	The claim is open-ended, meaning the composition must contain the required ingredients listed in the claim, and it could also contain other ingredients.	Client's composition contains 1% calcium and several other components not found in the claim.	Yes
30–40% of a nitrogen-containing component	Specification provides ammonium nitrate as the sole example of a nitrogen-containing compound.	Composition contains 35% nitric acid, a very common nitrogen source in fertilizers.	Probably yes
30–40% of a phosphorus-containing component	Originally filed claim contained the range 25–40%. Prior art reference cited during prosecution has composition containing 26% phosphorus. Applicant amended claim to the current narrower range. Therefore, <i>it is possible that in some jurisdictions 30% would be considered the bottom limit, and anything lower than 30% would not satisfy this limitation.</i> Other jurisdictions would find that a 1% difference is not significant and 29% is within the claimed range, despite the fact that the applicant amended the lower end of the range (i.e., the 1% difference is trivial).	Composition contains 29% of a phosphorus-containing compound.	Cannot determine. It would depend on whether the jurisdiction would find the 1% difference in the client's invention significant or trivial.
30–40% of a potassium-containing component	Specification mentions potassium chloride and several other examples of potassium-containing components.	Composition contains 31% potassium chloride.	Yes

**Conclusion:** Will depend on jurisdiction and interpretation of comparison.

**Teaching Example 18: Using a claim chart to show claim construction and comparison for a process claim**

Claim limitation	Claim construction	Corresponding structure in client's invention	Limitation satisfied?
A method for making a composition for use as a fertilizer	Preamble – a method of making a composition. Use as a fertilizer may or may not be limiting because the specification provides several alternative uses for the material.	Client is making a fertilizer composition.	Probably yes
comprising	Claim is open-ended – the method could include other steps and other ingredients, as well as the required steps and ingredients recited in this claim.	Composition contains 1% calcium and several other components.	Yes
combining	Specification states that combining includes combining by mixing, stirring, vibrating, etc.	Client's method involves mixing dry components.	Yes
30–40% of a nitrogen-containing component	See Teaching Example 17: the specification states that the order of mixing the components is not important.	Composition contains 35% nitric acid, a very common nitrogen source in fertilizers.	Probably yes
30–40% of a phosphorus-containing component	See Teaching Example 17.	Composition contains 29% of a phosphorus-containing compound.	Cannot determine
30–40% of a potassium-containing component to form a homogeneous composition	See Teaching Example 17.  Specification does not define homogenous.	Composition contains 31% potassium chloride.  Composition is granular – on a microscopic scale it is not homogeneous but on a macroscopic scale it is probably homogeneous.	Yes  Cannot determine, but probably yes

**Conclusion:** Will depend on jurisdiction and interpretation of comparison.



in addition to the similarities that caused them to be identified in the FTO search process.

For example, the client's invention has features A, B and C. In the FTO search, a patent document was retrieved because of matches with certain International Patent Classification (IPC) symbols (i.e., it was in the same or a similar technology area) and keywords describing features A and B. During your initial review of the claims, you see that the single independent claim recites an invention with features A, B, D and E. That means the claim would only cover (read on) an invention that has features A, B, D and E. You know the client's invention does *not* have features D or E. Likewise, your initial review of a claim might find that the claim is "closed" or the claim clearly excludes certain subject matter, and the client's invention includes features (structure, elements) that are clearly excluded from the claim. *In such a case, an initial comparison of the claim and the client's invention may allow you to find significant differences quickly and therefore avoid extensive claim construction.* Teaching Example 20 illustrates a quick comparison using a claim chart.

#### 4.4 Infringement analysis when claims include non-text features

Claims may include searchable non-text features that must be considered in infringement analysis. If the FTO search has returned potentially relevant documents based on a chemical structure search (e.g., using the structure search functionality of WIPO PATENTSCOPE), or searches for nucleotide or amino acid sequences (e.g., searching the Patent database of the GenBank sequence database using the BLAST functionality as described in Module III), then you will proceed with claim construction that includes a comparison of these features with your client's invention.

**For a chemical structure,** prepare a claim chart for the entire claim, including text and non-text features broken up and put in separate rows for construction and comparison. To construe the chemical structure shown in the claim:

- Determine the core structure and what substitutions (substituents, R groups, classes such as alcohol, halogen, etc.) or variations are allowed, if any.
- Determine if any substitutions or variations are clearly excluded.

To compare the chemical structures:

- Begin with a visual inspection and comparison with the chemical structure of the client's invention, to determine whether the core structures correspond.

- Review the list of permitted substitutions and determine if the client's invention can be made using the claimed core structure and permitted substitutions, in which case the limitation may be satisfied.
- If certain substitutions are excluded, determine whether the client's invention could be made using excluded substitutions, in which case the limitation would not be satisfied.

In some cases, substitutions are defined by functionality in the claim or specification, but the functionality of the substituent at the corresponding location in the client's invention is unknown, in which case it may be unclear or even impossible to determine whether the limitation is satisfied.

**For nucleotide or amino acid sequences,** extract the sequences that were identified by the FTO search, and the relevant sequence in the client's invention. To compare the sequences, you may be able to accomplish some tasks "manually" (visually), while you may need to use tools for other tasks.

- Start by inspecting defined features such as length, the occurrence of a specific residue at a defined location (a residue may be a nucleotide, amino acid, short sequence or variant) or the requirement that the sequence be obtained from a specific organism, and then compare the feature from the patent document with the corresponding feature in the client's invention.
  - If a limitation is defined in flexible terms such as percent identity or percent homology to a sequence, then you may need to use a tool such as BLAST to align and compare the sequences.
  - If the claim recites homology, claim construction may require determining whether the specification identifies the version of the BLAST algorithm that was used, in order to ensure that the same algorithm is used for the comparison step (if possible).
- Based on the outcome of the alignment and comparison, determine whether the client's invention is within the level of identity or homology required by the claim limitation.

#### Recap

**You need to understand the types of claims, the structure of claims, and the functions served by claims in order to evaluate whether a claim could or might cover (read on) your client's invention and present a potential FTO issue.**

**Each claim in a patent document that was identified as potentially relevant during an FTO search should undergo infringement analysis. Start by analyzing the independent claims.**

**Teaching Example 19: Using a claim chart to show claim construction and comparison for a method of use claim**

Claim limitation	Claim construction	Corresponding structure in client's invention	Limitation satisfied?
A method for using the composition of claim 1		Client is making a fertilizer composition with packaging instructions that describe recommended use.	Cannot determine. The client may not actually "use" the fertilizer.
comprising	Claim is open-ended.	Packaging instructions indicate several recommended steps.	Yes
applying	Specification states that applying includes spraying as a solution or applying the composition directly as a solid.	Packaging instructions indicate that the composition should be applied in a solution.	Cannot determine. The client may not apply the fertilizer. The "applying" step is likely to be carried out by the end-user (e.g., a farmer).
the composition of claim 1	As in Teaching Example 17.	As in Teaching Example 17.	Probably yes
to a plant or to soil	Specification provides a non-exhaustive list of plants that benefit from the composition.	Packaging instructions indicate application to several plants that are listed in the patent specification and several that are not.	Probably yes
in an amount suitable to enhance the growth of a plant	Specification provides ranges as guidance on dosage – specifically, 1.5–2.5 kg/acre.	Packaging instructions indicate dose range of 1–2 kg/acre (partially overlapping the patent specification).	Probably yes

**Conclusion:** Will depend on jurisdiction and interpretation of comparison.

**Teaching Example 20: Carrying out a comparison step before claim construction**

The claim recites “A table comprising a flat surface and four legs attached to the flat surface, further comprising a drawer attached to the flat surface.” Your client’s invention is a table with a flat surface, four attached legs and a footrest.

Claim limitation	Corresponding structure in client’s invention	Limitation satisfied?
A table	A table – same type of invention	Yes
comprising	(with)	Yes
a flat surface	a flat surface	Yes
four legs attached to the flat surface	four legs attached to the flat surface	Yes
a drawer attached to the flat surface	Client’s table does NOT have a drawer. Client’s table does not have any other structure attached to the flat surface, besides the legs.	NO – because client’s table does not have a drawer.
	a footrest	Not applicable/not relevant. (The claim is open-ended, so a footrest is not required and is not excluded.)

**Conclusion:** Does not appear to cover the client’s invention (Category 3, see section 6.1. “Classify each claim”).

**Infringement analysis is a two-step process that involves:**

- **Determining the scope of the claim or claims of interest (claim construction)**
- **Comparing the construed claim with the product or process being analyzed (for example your client's invention) to determine whether the claim covers (reads on) the product or process.**

**You must consider mandatory sources of information – including the claim language, patent specification, file history and litigation records – when construing claims.**

**If you cannot determine the scope of a claim using mandatory information sources alone, optional sources of information – such as dictionaries and prior art references – can also be considered.**

**Claim charts will help you to represent a claim and match claim elements with potentially corresponding elements in your client's invention.**

### Terminology hint

**Geographically isolated** means that the product/process will not leave the specified country/region, and will not reach any jurisdiction where a patent is in force (e.g., via export). This may be a particularly tricky requirement for software-type patents that involve online activities, since such activities do not generally respect physical borders.

### Terminology hint

Although the term **valid and enforceable** is often used to refer to a patent that is **alive and in force**, this term can be confusing because there are circumstances in which a patent is still legally valid but is unenforceable. For example, a patent owner disclaimed the right to enforce a valid patent by dedication to the public, or stopped paying renewal fees for a patent, or the patent owner is found to have engaged in inequitable conduct. In these cases, the patent rights have been extinguished by events that are not related to the legal validity of the patent.

## 5. Determining legal status

As discussed previously, determination of legal status rests upon the principle that patents are territorial and time-limited, meaning they can only be enforced in the country of grant, with respect to activities in the country of grant during the time the patent is in force. If the product or process being evaluated in an FTO analysis is geographically isolated to a defined country or region, then patents granted in countries outside of that country or region are not relevant and need not be reviewed.

The legal status of a patent refers to whether it is **enforceable**. A granted patent can be referred to as “alive” or “in force” at a given time, which means it is enforceable in the country of grant at that time. A granted patent can be “dead,” which means it is unenforceable, either because it expired at the end of its full patent term or because it became unenforceable before the end of a full term due to being abandoned, withdrawn, revoked, invalidated, disclaimed, dedicated to the public, unenforceable due to inequitable behavior of a patent owner, or otherwise unenforceable. The legal status of a granted patent can be ambiguous or unsettled.

The legal status of a **patent application** refers to whether the application is still pending, such that a patent might eventually be granted from the application. A patent application can be pending, canceled, withdrawn or abandoned. Future legal status is unknown, although a predicted expiration date can be calculated based on the filing date.

It is important to determine the legal status for FTO analysis because a potential FTO issue can only arise if a claim that could cover an invention is found in an enforceable patent that could be asserted in an infringement proceeding. If a claim is found in an unenforceable patent, then it could not be asserted in an infringement proceeding related to

an invention, even if infringement analysis indicates that the claim could be found to cover the invention.

## 5.1 Patent term, expiration and abandonment

Patents are issued with a fixed term that can vary based on jurisdiction as well as on activities of the patentee, courts, and actions by the local patent office. Patent rights are extinguished automatically when the patent expires at the end of its full patent term and the patent becomes unenforceable. In countries that are compliant with TRIPS, patents have a normal patent term of 20 years after the effective filing date. A variety of factors can extend or shorten patent term, as discussed below.

Although this guide does not directly address FTO analysis of other instruments such as utility models, petty patents, innovation models or mini-patents, you should note that the term of these instruments may range from 5–15 years and may be based on the grant date rather than the application filing date.

Patents are living documents, and their legal status or scope can change over time. The scope of granted patent rights can change before the end of the full patent term if the patent or certain claims of the patent are invalidated, disclaimed, abandoned or withdrawn, or if the patent is found to be otherwise unenforceable. In some circumstances, claims may be amended after grant and their scope will change. The legal status of almost any enforceable patent can change, for example due to future litigation, non-payment of renewal fees, incorrect entity status of the owner, abandonment, or a disclaimer that results in extinguishing the patent rights before the end of the full term.

In some circumstances, it is not possible to determine the legal status of a patent or patent claim because years may pass before the final scope of patent rights is resolved. This can happen, for example, if a patent is involved in post-grant proceedings or litigation, or if an abandoned patent is within a revival window. In some circumstances, an abandoned patent (or patent application) can be revived years later, and the exclusive patent rights granted by the patent come back into force.

### How patent term can be reduced

Patent term is reduced if the patent is abandoned, withdrawn, invalidated, disclaimed or otherwise found to be unenforceable.

The most common way for a patent to be abandoned is by failure of the patentee or patent owner to pay renewal fees. Payment schedules of renewal fees may be based from the application filing date or from the patent grant date. Typically, a grace period will be allowed, such as a six-month window during which time the renewal fee (and possibly a penalty fee) can be paid.

In some jurisdictions, it is possible to revive a patent that expired for failure to pay the fee even after the grace period has expired. The length of the revival period may or may not be specified in the local patent law. In some cases it is possible and relatively simple to revive a patent, even long after it has expired for failure to pay renewal fees. In other cases, revival may not be a matter of right, and may require (for example) a petition and a showing of unintentional abandonment. Due to such variations, FTO analyses should be cautious of concluding that patents from certain jurisdictions are expired.

Some jurisdictions record payments of renewal fees using an online system that allows third parties to search for and obtain payment records. In other jurisdictions, the physical file may be the only record of payments of renewal fees.

Patent term can be reduced by disclaimer or explicit abandonment. In some jurisdictions, a terminal disclaimer may be required when a patent application is deemed to have claims with nearly the same scope as those of a co-owned patent that will expire sooner. A patent owner may choose to dedicate certain subject matter to the public by disclaiming some or all of the claims for the remainder of the patent term of an unexpired, valid and enforceable patent, and making a statement that the disclaimed subject matter is dedicated to the public. Remember though, as discussed in Module I, this only means the patent owner has given up their right to enforce their patent, while other patents that cover features of the invention may still be in force.

### How patent term can be extended

The effective term of a patent can be extended by discretionary or statutory procedures granted by patent offices. A common reason for patent term extension is to compensate a patent owner for delays caused by obtaining required regulatory approvals from one or more offices of the government. For example, pharmaceutical products often require approval from one or more government offices (e.g., the Food and Drug Administration in the United States of America or the Pharmacy and Poisons Board in Kenya), and obtaining such approval may require a significant amount of time, during which

the patentee cannot sell the patented product. Patent law in the United States of America includes a provision for recapturing some of that regulatory approval time delay through patent term extension, and it also recognizes that the patent office may delay in carrying out certain functions such as issuing examination reports, so that the patentee is permitted to recapture qualifying delay time with a patent term adjustment. Patent offices use different mechanisms to extend the effective patent term. For example, USPTO procedures extend the term of the original patent, whereas Member States of the European Union utilize a Supplementary Protection Certificate (SPC) that enters into force after the original patent has expired. Thus, it is important to check the administrative records of a patent to determine if any patent office actions have extended the effective term of patent rights.

#### **Post-grant proceedings that can affect patent term**

A further complicating factor is the potential for post-grant proceedings before a patent office, an appeal board, a court of law or other decision-making body that may change the legal status of granted patent claims. Some jurisdictions allow for post-grant oppositions in which a third party can challenge the grant of the patent by the patent office. The USPTO, for example, offers several types of post-grant proceedings, including *ex parte* reexamination, *inter partes* reexamination, reissue and post-grant review. Each process follows separate rules and procedures. The EPO also provides for opposition proceedings, and the European situation can be complicated by the potential for multiple and simultaneous national-level court proceedings. Various other countries, such as Brazil, Japan and South Africa, also allow post-grant proceedings.

After such proceedings, patent claims may be upheld and deemed valid as granted, or they may be amended, canceled or otherwise invalidated. Depending on the type of proceeding, the entire patent may be found unenforceable, or only certain claims in the patent may be found unenforceable. When post-grant activities are carried out by the patent office, such outcomes should be present in the file history of the patent. When post-grant activities are carried out before a court or tribunal outside of the patent office, it may be necessary to locate and review the decision of the court or tribunal in order to determine the legal status of the patent.

#### **Predicted patent term for pending applications**

As previously discussed, during the FTO search you may have identified a pending application as a potentially

relevant patent document. In such a case, you should predict what the full patent term of a patent granted from the application would be, based on the effective filing date. Although you do not know whether any patent will be granted from an application, and you also do not know what the final scope of the patent claims will be, it may nevertheless be useful to alert your client to *potential* patent rights that could come into effect in various countries, and their potential terms in force.

## **5.2 Other factors to consider in determining legal status**

The legal status of a claim in a granted patent may be ambiguous or unsettled. For example, some jurisdictions may have a mechanism to extend the deadline for revival of an abandoned patent, in which case a patent that was previously reported as abandoned might be revived. Patent records may be unavailable, lost or destroyed. Furthermore, in some cases it may be important to know the identity of the patent owner, for example to determine who has the power to enforce the claims against potential infringers. It may be difficult to determine ownership because some patent offices do not keep accurate assignment and ownership records. In some cases, a new patent owner may not record a change of patent ownership in the register of the patent office.

In pending patent applications, the legal status of each claim might change at any time during the examination and appeal processes. During examination, the application can be expressly abandoned by the applicant, or it can become abandoned due to inaction by the applicant (e.g., failure to pay an annual fee, failure to respond to an examination report) or it can be under final rejection by the patent office, including loss on appeal. You will need to check the legal status of an application by referencing the file history either online (where available) or in person at the patent office. Thus, the FTO analysis should clearly state the date when the legal status of a pending application was checked.

In view of the above discussion of patent term, it is important to determine the period of time within which the client plans to sell, manufacture, import, export, or otherwise use their invention, or whether the client has already performed any of these activities. Portions (or the entirety) of such periods may be outside of the time during which the patent is enforceable, and should be addressed in an FTO analysis. For example, if the FTO determination identified a potential patent of interest that will expire in two years and the client plans to launch their product *after* the expiration date, then that patent may not be of concern to the client.

### 5.3 Sources of information for determining legal status

The national or regional patent register of the granting patent office is the authentic source of legal status data for a patent and should be your first source of information.

- The WIPO Patent Register Portal (see Annex D) has been designed with the aim of facilitating legal status searches and making legal status information more accessible and harmonized. The WIPO Patent Register Portal is a repository of information about online patent registers, and provides direct access and links to national and regional online patent registers and patent information collections.
- National patent office websites may have patent term calculators, or may include the predicted patent term and expiration date in the record of a patent document; however, it is important to check the record of actual events to determine legal status.
  - The USPTO and EPO have extensive online searchable records for legal status, annual fee payments and file histories, and other national patent offices have similar online databases.
  - For those offices that lack the relevant information in searchable format, electronic or telephonic inquiries may be sufficient to retrieve this information. Rarely, a visit to the office may be required.
- The International Patent Documentation (INPADOC) database, maintained by the EPO, is another source of legal status information. INPADOC presents patent family information that shows relationships between corresponding patents for a large number of patents from patent offices around the world.

In some cases you may be able to consult two different sources to determine legal status of a patent, and in such cases you should aim to confirm consistency among the sources.

Regarding payments of annual fees, some national patent offices provide such information online, whereas other patent offices release such information only upon request. Where a patent database indicates that a patent has expired for failure to pay fees, take care to determine whether there is any opportunity to revive or reinstate the patent under the relevant patent laws, by payment of the fees owed and additional revival fees.

Regarding court cases or administrative actions that render a patent unenforceable, or enforceable under modified terms (e.g., based on amendments to the claims that could change their scope), it is important to ensure that you have found the most recent decisions and actions. For example, if you find a court-issued decision on the validity of a patent, it is necessary to determine whether the decision was appealed, and whether appellate review of the decision has been conducted, in order to determine whether the decision is final or whether it could be reversed or vacated on appeal.

#### Helpful hint

Although some privately operated patent databases provide legal status identifiers that can be used for searching or sorting patent documents, it is important to remember that these databases are secondary sources that may not be accurate or up to date. A final determination of legal status should be based on confirmation using authentic data from an official patent register, if possible.

## Recap

**You need to determine the legal status of a patent or patent application for FTO analysis because a potential FTO issue can only arise if a claim that covers an invention is found in an enforceable patent.**

**National or regional patent registers at the granting patent office are the key source of information regarding the legal status of a patent and can often be accessed online.**

**Bear in mind that there may be opportunities to revive or reinstate patents, which may then present potential FTO issues.**

## 6. Making final determinations

FTO analysis involves using standard tools according to the current understanding of applicable law and doctrine, to make informed guesses about what might happen in a hypothetical future situation in which the client had been accused of infringing the claim being analyzed. Any final determinations you make represent the interpretation you applied when you used these tools to construe claims and compare them with the client's invention, and the interpretation you applied to any facts relevant to legal status.

### 6.1 Classify each claim

Assign each claim to one of the following categories:

#### 1. Could be interpreted to cover client's invention.

You conclude that most experts would probably interpret the claim in a way that would find that it covers the client's invention.

#### 2. May be interpreted to cover client's invention.

There is a possibility that the claim could be rationally interpreted to cover your client's invention.

#### 3. Does not appear to cover client's invention. The client's invention appears to lack a structure or element that corresponds to a required limitation in the claim and the claim limitation is not satisfied. Or, the scope of one or more of the essential features of the client's invention lies outside of the scope of an otherwise similar limitation of the claim.

#### 4. No determination can be made. You can assign this category if there is substantial ambiguity in the

claim scope, or there is an uncertain or unknown element in the client's invention at the time you carry out the FTO analysis. For example, the scope of a claim limitation may be ambiguous, and the specification and prosecution history may not provide enough guidance. Or, you may have insufficient information about a feature in the client's invention, such that you cannot reach a conclusion when you compare the claim with the client's invention.

### 6.2 Classify each patent

You should then classify each patent document that contains the claims you analyzed and classified. Patents can be classified as follows:

- **Patent of interest.** This is a patent with at least one Category 1 claim or Category 2 claim. A patent of interest can be:
  - **Patent of interest – in force.** This is a patent that would be in force in a country where the client plans to use the invention at a time when the client plans to use it. Clearly identify the expected expiration date. These patents should be pointed out to the client.
  - **Patent of interest – expired/unenforceable.** This is a patent that has at least one Category 1 or Category 2 claim that could have raised FTO issues, except that the patent is expired or unenforceable and therefore can be dismissed. For example, if the client copied their invention from a patent and the patent has since expired, then your FTO search should have found that patent and the FTO analysis should have identified at least one Category 1 claim in that patent and the patent is identified as a “patent of interest – expired” or “patent of interest – unenforceable” in your final determination. You can decide whether you want to discuss these patents with your client because they contain relevant information, but cannot be enforced.
- **Not likely to be of interest.** This patent contains only Category 3 claims. The client should know that the FTO search identified these patents, but analysis did not find any significant FTO issues.
  - **Not likely to be of interest – in force.** This is a patent that is in force in a country where the client plans to use the invention at a time when the client plans to use it. You have the option of showing how FTO analysis distinguished between the patented invention and the client's invention.
  - **Not likely to be of interest – expired/unenforceable.** These patents need the least discussion, because they are patents with claims that are significantly different from the client's invention and are not in force.



- **No analysis of claims because patent is expired/unenforceable.** Use this classification to identify patents where you did not carry out infringement analysis of claims because you determined legal status first and found that the patent is not in force. For each patent, point out whether it expired at the end of a full term or became unenforceable before the end of the full term. (Confirm status using authentic data from a national or regional patent register.)
- **No determination can be made.** You cannot determine whether this patent has any claims that could have a potential impact on the client's freedom to use the invention as planned. Use this classification when you cannot reach a conclusion after infringement analysis, whether due to unclear claim scope or uncertain/unknown elements in the client's invention, or both. You can also assign this classification when the legal status of the patent is ambiguous or unsettled. You have the option to discuss these patents with your client, even though you could not reach a final determination.

## 7. The Final Report

You will typically communicate the conclusions of the FTO search and analysis process to the client in a Final Report. The report should include:

- a summary of your understanding of the invention and its planned use
- your FTO search strategies
- a summary of the FTO search
- a list of patent documents that you analyzed
- the results of FTO analysis
- the conclusions you reached.

Your report should contain sufficient caveats and explanations to help your client understand the limitations of what FTO analysis can accomplish. (See the discussion of limitations of FTO search and analysis in Module V.) The report should discuss the limitations and potential errors inherent in using the principles and tools taught in this guide. As discussed elsewhere, your report does not reach legal conclusions or provide legal advice, and you must not make legal statements.

You should treat the report as confidential, and should mark it accordingly. However, because you are *not* an attorney or patent agent or other legal professional representing a client, and because the report is not prepared in the course of providing legal services to the client, the report should not be considered to be subject to laws that apply to attorney–client communications. The client is free to treat the report as confidential, or to treat it as non-confidential and share it freely with other parties.

The format of the report may depend on the conclusions of your analysis. A template for the Final Report is provided at Annex C.3. The following remarks indicate what you should include in the report, and provide guidance to help you prepare the report.

Finally, do not provide advice to the client in this report. The purpose of the report is to communicate information to the client, and the client is responsible for considering this information as they make decisions to proceed with their plans.

### Helpful hint

A client may want a definitive statement as to whether they are, or would be, infringing any enforceable patent. Similarly, a client may want a definitive statement as to whether their invention is in the public domain. This guide is not written to address these expectations. Instead, this guide is written to provide training and tools to help you undertake information gathering, FTO search and informal FTO analysis, and to communicate your findings to the client.

Therefore, conclusions from informal FTO analysis should be expressed in terms of the *likelihood* that a claim *could* or *might* be interpreted by experts to cover (read on) the client's planned use of the invention. Use language that refers to the *possibility* that a claim *could* or *might* be found to cover (read on) the client's invention. *Do not use legal terms* such as **infringe** or **infringing** or **non-infringing** in connection with your findings about the client's invention. You are not rendering a legal opinion.

## 7.1 Summary of the invention

It is helpful to begin with a description of the client's invention. This summary can be based on information and analysis you included in the Summary Report prepared in Module II, and can also include any additional understanding of the invention you have gained during the remainder of the process.

This description is important for two reasons:

- It helps to explain the FTO search results and FTO analysis being discussed in the report.
- It allows the client to see how you understand the invention.

## 7.2 Summary of FTO search

The report should include a brief summary of the FTO search, explaining the decisions that you took and the strategies that you used. Describe the mechanics and the results of the search, including:

- databases searched
- subject matter searched (e.g., claims, abstract, anything else)
- search terms and patent classification symbols you used for searching, including how they were combined
- other types of searches you carried out, such as for non-text features, or for specific inventors or companies
- any time limits on the search
- number of patent documents identified
- number of patent documents selected for FTO analysis.

The summary may also identify what was deliberately omitted from the search, with brief explanations of your reasoning behind the omissions. It may include bibliographic details and brief citations or images from potentially relevant portions of patent documents. Unless requested by the client, the summary of the search does *not* include raw search data or the full results from the FTO search.

## 7.3 FTO analysis

You have to choose how to organize the main body of the report, in order to present information in the way that will be most useful to your client. Some ways of organizing the report are listed below.

- **Ranking.** One option is to organize the report in order of perceived relevance, where patents that you identified as raising potential FTO issues are discussed first.

- **By country.** If the client has identified multiple countries of interest, then the report could be organized on a country-by-country basis, with a separate section for each country that includes a discussion of the patents, issues, timelines and so on for that country. You will probably want to organize the patents in each country-specific section according to ranking or by expiration date.
- **By feature.** Another option is to organize the report by invention features, with separate sections for each feature. For example, if the client reported that the invention uses a patented component, then you may want to focus on the feature that uses that component.
- **By time frame.** If the client is concerned about when to launch their product, the report could be organized by time frame of any patents that raise potential issues. You could rank patents within this section by predicted expiration date.

### Contents and organization

- You should identify *all* the patent documents that you considered during the FTO analysis step.
- If you analyzed claims of any patents (or applications), then you should identify *all* the claims you analyzed in each patent (or application).
- You should include all of the patents that you identified as expired or unenforceable, even if you did not analyze the claims of those patents.
- If you also analyzed patent applications, include them and emphasize that claims in patent applications only represent *potential* future patent rights.

One option is to prepare a master list of *all* the patent documents that you analyzed, arranged in table format with one patent document per row. The table should include bibliographic data, legal status (“in force” or “expired” or “unenforceable” or “cannot determine” or “did not determine”) and remarks on the analysis you carried out (e.g., whether you carried out both an infringement analysis and legal status determination, or just one). This provides a useful summary of the FTO analysis. If you make a master list, you can provide a detailed discussion of the most relevant patents in a separate location in the report.

In the Final Report, you should include a brief mention of *all* the patent documents you considered (e.g., in a table as suggested above). You should provide more detailed discussion of the patents (and applications, if any) that you think are most relevant to your client's planned use of the invention. These are the patent documents that you want to point out to the client, so they can consider this information and decide how to proceed.

The entry for each patent document should be by number and title, country of grant, legal status and predicted expiration date, and you should provide links to any electronic documents. The entry could include additional bibliographic information such as inventor(s), owner(s) and priority claims. List the claims that you analyzed, at least by claim number or with claim text if feasible, and conclude with remarks on the results of infringement analysis for each claim that you analyzed (claim classification). Optional information could include patent family information (if any), a list of IPCs that matched search terms, and excerpts of relevant text that shows where search term matching occurred.

### Report of FTO analysis

For each patent that you discuss in detail, decide whether you want to include claim charts and discuss the infringement analysis and legal status determination for each claim. You can decide whether to include a claim chart for *each* claim you discuss, or only for certain claims of interest. You should include any additional information that you consider to be useful to the client.

A detailed discussion of the analysis is probably not necessary for patents that you classified as “not likely to be of interest” or “no analysis of claims” in your final determination. If multiple patents showed clear differences with the client’s invention, it may be sufficient to list these patents in a table with one patent per row, and provide brief comments on these differences.

### Report sources of information

If you had to consult multiple sources of information to construe a claim, you may want to report what actions you took, such as reviewing the file history or making a detailed analysis of the specification. This can be included as a separate paragraph, or as a section of your discussion of infringement analysis of a claim.

## 7.4 Option for additional analysis

Your report could include an additional analysis of patent rights that may be relevant to your client’s invention. You could discuss similarities between your client’s invention and various claimed inventions, which may indicate features that are more likely to trigger FTO issues. These may be features that your client could consider changing, such as using a distinct alternative or “designing around” the feature if possible.

You may also choose to point out circumstances where FTO search and FTO analysis *did not* find enforceable

patent rights around the client’s invention. You should state the specifics of each circumstance, for instance that the FTO search did not find any potentially relevant patent documents, or that even though the FTO search found potentially relevant patent documents, subsequent FTO analysis did not find any claims that appeared to cover the client’s invention. The client will find it helpful to know about circumstances where no potential obstacles were identified.

## 7.5 Conclusions

You should prepare the conclusions section *as if it is the only section that the client will read in detail*. Include a summary of the most important results and the most significant details of the analysis, and emphasize the information that you want the client to take away from this project.

### Report your findings using technical language.

Your report should state that you applied the tools of FTO analysis in a technical way to reach a determination based on available knowledge and facts. You should continue to use technical language and carefully state whether you did, or did not, find patent documents with claims that you classified as “could be interpreted to cover” the client’s invention (Category 1) or “may be interpreted to cover” the client’s invention (Category 2), such that the patents were classified as “patents of interest” and their legal status was determined.

**Do not use legal language.** *Do not* make statements such as that a patent “presents no FTO risk” or “presents a definite FTO risk” or that “no FTO risks were found” after analysis. *Do not* make statements such as you found “infringement” or “non-infringement” of any claim. These statements may be interpreted as legal conclusions that you are not in a position to make. This report is not a legal opinion on FTO prepared by a legal professional, and therefore such statements are not appropriate or permissible for this report.

Instead, report your findings and *draw the client’s attention to patent documents that you think are relevant*, especially patents classified as “patent of interest – in force” in your final determination. (You may also want to point out pending applications that should be monitored.) Briefly restate the reason you determined that one or more claims in these patent documents “could be” or “might be” interpreted to cover a planned use of the invention. If you found useful results in expired or unenforceable patents, you should briefly restate these results for your client’s information.

Restate any issues that remain ambiguous or unsettled. Point out circumstances where you could not reach a firm conclusion or make a final determination with respect to issues such as infringement analysis or legal status.

If you choose to discuss any circumstances where the record suggests the invention may be in the public domain, explain your reasoning and restate the uncertainties and potential for error associated with identifying inventions in the public domain.

Be sure that your conclusions are entirely consistent with the body of your analysis and any other statements you make throughout the report.

## 7.6 Risks and limitations

Close the report with general remarks about the limitations, potential errors, and risks associated with the FTO process. You can find disclaimers in Module V. Also include any remarks that are specific for the project, for example regarding database accessibility or contents, issues related to language or tools, or access to information for determining legal status.

If you conclude that the record suggests the invention may be in the public domain in a specific country during a defined time frame, then discuss the uncertainties and potential for error associated with identifying inventions in the public domain. This discussion should include general principles as taught in this guide, and specific circumstances related to the project.

Include a final reminder that your report is merely a report of technical analysis and does not provide legal or business advice. The purpose of the report is to provide information and it is not a substitute for the advice of a qualified legal professional. Clearly state that your client is responsible for considering information provided in the report and deciding how they wish to proceed.

### Recap

**Remember that you are carrying out an informal FTO analysis, so express your conclusions in terms of the likelihood that a claim might or might not be interpreted by experts to cover (read on) your client's planned use of the invention – do not use legal terms or language.**

**Your Final Report should communicate the results of your FTO search and analysis process to the client, and should not provide advice. The client is responsible for considering the information you have communicated and then making their own decisions about how they wish to proceed.**

# Module V

## Understanding limitations and risks associated with FTO determinations: Risk management and how to use results

### 1. Introduction

In an ideal system, a completely accurate definition of the invention is used in a completely comprehensive search and analysis process that reliably identifies any and all patent rights that cover use of the invention as planned. In such an ideal system, finding public disclosure of the invention and not finding any patent rights that cover use of the invention as planned would be taken as a finding that the invention is in the public domain for purposes of using the invention as planned, in a specific country, during a specific time frame.

In actual practice, FTO determination is associated with a great deal of uncertainty and potential error at each stage. It is important to understand the sources of this uncertainty and potential error, in order to manage risks associated with FTO determination. Technical error can arise from how the invention was described, and how information was entered into and retrieved from databases. The FTO search is sensitive to factors such as the quality and content of the databases that are searched, the timeliness of database contents, the accuracy of search inputs, the scope of the search, and the quality of support tools such as translation or classification functions. Uncertainty or error is associated with using the tools of infringement analysis, due to factors such as the ongoing evolution of patent rules and standards in each country. As a result, it can be difficult to confidently conclude that an invention using current technology is covered by one or more enforceable patents, or that an invention is in the public domain.

Thus, an understanding of these sources of uncertainty and potential error will help you manage the risks associated with FTO determination and, by extension, the risks associated with identifying inventions in the public domain.

#### Learning points

Once you have completed this module, you should understand how to:

- Recognize sources of uncertainty and potential error in the FTO determination process as a whole, and at each stage.
- Evaluate what steps you can take to manage the risks associated with the FTO determination process as a whole, and at each stage, with the understanding that these risks cannot be eliminated.
- Use determinations in the Final Report to provide information for the client to use for deciding how to proceed, in view of the associated risks.
- Evaluate whether certain circumstances are appropriate for identifying an invention as being in the public domain, in view of the associated risks.

## 2. Uncertainty associated with the premise of FTO determination

The fundamental premise of FTO determination is a source of uncertainty for the entire process. FTO determination depends on assuming that it should be possible to:

- accurately deconstruct the invention and develop comprehensive search strategies
- access information in patent documents in which all relevant information is available for searching
- carry out a comprehensive search that would find all relevant patent documents
- correctly interpret (construe) all claims to differentiate between patents that do and patents that do not have the potential to interfere with the client's freedom to use the invention as they have planned.

Starting from these idealized assumptions, FTO determination employs a forward-looking process that tries to imagine potential problems related to the invention, find patent documents that might create potential problems and then predict what might happen if those potential problems ever became actual problems. Thus, you face the challenge of using standard tools for searching and analyzing patent documents, according to the current understanding of applicable law and doctrine, to make informed guesses about what might happen in a hypothetical future situation that might occur if the client were to be accused of infringement, without knowing the grounds and particulars of the accusation.

## 3. Limitations and risks associated with identifying information needs (Module II)

It is essential to understand the client's invention and the underlying technology. If you do not completely understand the invention technology, the subsequent FTO search may be seriously deficient and you may miss significant patents. Even if your analysis of the invention technology is only slightly off-target, you could fail to retrieve some potentially relevant patent documents, or fail to recognize relevant documents among the search results.

Therefore, you should first understand the invention in all its aspects and then, in a separate step, identify the features that are essential for identifying and selecting relevant documents. Generally, you will learn details of the technology by conducting the activities described in Module II, which include:

- face-to-face, telephonic or electronic interactions with the client
- reviewing an invention disclosure form or other

documentation prepared by the client to describe their technology

- evaluating a sample or model of the technology
- your follow-on analysis.

In some cases, you may have additional resources available, such as results from previous patentability, novelty or "state-of-the-art" searches related to the client's invention. Publicly available patent landscapes for relevant technology areas may be a useful source of information. Guidance for classification symbols and keywords for FTO searches may be found in previous searches and patent documents identified in such searches.

**Risk management.** It may seem attractive to start searching as soon as you have grasped the general idea of the client's invention, with the expectation that you will gain a deeper understanding of the invention while searching. Instead, take time to understand the invention and associated technology as thoroughly as possible before starting the FTO search stage. You may need to carry out additional research to understand the relevant technology. Finally, as recommended in Module II, try to draft patent-style claims to describe the invention as if you were seeking patent protection for the invention. This should help you identify the essential features of the invention, which will help you deconstruct the invention in the FTO search stage.

## 4. Limitations and risks associated with FTO searching (Module III)

The FTO search relies on the accuracy of the search inputs, the quality and content of the databases searched and the quality of support tools used in the search, such as translation or category identification tools. There are limitations associated with the search process and limitations associated with the data.

### 4.1 Limitations of the search process

The FTO search is a complex process with many potential limitations and sources of error. The accuracy of a search depends on proper deconstruction and classification of the invention, and how well you use this deconstruction and classification to develop a search strategy. Potential problems include:

- Keywords used in the search may not map to the terms used to describe the same or similar features in other documents, such that potentially relevant documents may be missed. Overly broad keywords

may return too many documents, making it difficult to find the potentially relevant results.

- Patent classification symbols may not be accurately assigned. Use of too many symbols may result in an unfocused search that retrieves too many documents.
- Search string development and testing (search string optimization) is an empirical process with no objective measure of success. You have to review initial search results and modify the search string in view of the results you have before you. If the search string is skewed away from the “core” of the invention, further optimization could skew it more. Tools for search string optimization will generate suggestions or information based on empirical association models that are not necessarily trained on data sets similar to the invention you are searching.
- Optimization of a hybrid search that uses keywords and International Patent Classification (IPC) symbols may run the risk of defocusing the search instead of focusing and refining it. Use of certain keywords to generate IPC suggestions may result in suggestions that skew the search focus away from the core of invention.
- The scientific lexicon can be very involved and complicated. A search algorithm can retrieve a wide swath of patents with similar claim elements. Limited technical or legal understanding can limit your ability to aggregate the patents into appropriate clusters to get the needed view of the patent rights covering the client’s invention.

**Risk management.** You can overcome some of the limitations of the search process by using the various options provided by the specific databases. PATENTSCOPE provides disambiguation tools that help the search process, including:

- translations at various levels
- query saving and break-up (query tree)
- the availability of images
- temporal and spatial coverage
- improved deconstruction using WIPO Pearl, International Patent Classification Categorization Assistant (IPCCAT), term search and catchwords
- use of wildcards for keyword optimization in formulating the search or broadening the scope of the search.

By using these tools, it may be possible to manage and mitigate some of the limitations arising from the search process.

Another approach to risk management involves a commitment to extensive search and review. This can take the form of searching more than one database and reviewing as many search results as feasible.

## 4.2 Limitations inherent in the data being searched or retrieved

Data in a database may be inaccurate and therefore a correctly structured search may not find it. Data retrieved from an FTO search is not always error-free. Potential problems include:

- misspellings
- alternate spellings, especially of names and assignees/owners, or in transliterated words or names
- inconsistency in classification of patent subject matter
- translation errors, especially for Japanese, Chinese and Korean documents, and some European patent documents
- duplication of results
- timeliness and completeness of updates. For example, the International Patent Documentation (INPADOC) database contains patent information from many countries. Different countries use different update schedules that can vary from two weeks to one year, and report different types of information. Not all countries report legal status, and it is not always possible to verify the filing or legal status of a patent application in national patent offices
- access to new information and ongoing developments. Patent bulletins and gazettes have the latest developments and patent news, but there is generally no mechanism for regular updates. Patent retrieval from databases often does not include updated information found in file wrappers, patent registers and journals.

**Risk management.** Detailed manual review of the search results is best, as you are in a good position to detect and correct errors and normalize data (e.g., obvious misspellings, abbreviated names or garbled text indicating a translation error). However, you can supplement this approach by using data normalization and data cleaning processes. If the search results have been entered in an Excel document, you can address duplication using the Excel de-duplication function; you can use other functions in Excel to clean up or improve visualization of results. Specialized data cleaning software is also available. Set up RSS feeds where possible to actively push out new information relevant to FTO determination. Many of the approaches associated with risk management at this stage are technically specialized. However, you should consider yourself to be the final authority on whether you have addressed data-associated risks.

## 5. Limitations and risks associated with FTO analysis and the Final Report (Module IV)

As noted above, the ultimate goal of the FTO analysis can be likened to anticipating the results of a hypothetical future litigation or similar proceeding, where you have to guess what grounds might be asserted to make an accusation of infringement, and you also have to guess what analysis would support a favorable outcome for each side.

An actual infringement litigation (or similar proceeding) would involve expert opinions and evidence from authoritative sources on both sides of the dispute, and the question of infringement would ultimately be determined by a judge, jury or other decision-maker (depending on the jurisdiction). Any such determination inherently involves a measure of unpredictability in the outcome.

Here, you are applying general principles of infringement analysis in a technical manner, to analyze patent documents from multiple jurisdictions according to the current understanding of applicable law and doctrine. You are applying these general principles to interpret a claim and compare it with your client's invention, in order to make an informed guess about the likelihood of experts in a hypothetical future litigation interpreting the same claim in such a way that it would be found to cover (read on) the client's invention, and whether the client's invention would be found to infringe the claim and the patent where the claim is found.

In addition to the challenge of envisioning a hypothetical infringement litigation, potential problems arise from the fact that applicable laws and regulations may change. Rules and standards that apply to claim construction and infringement analysis constantly change. Ongoing judicial interpretation continues to shape the legal standards that may apply to these analyses. Different decision-making bodies may apply different claim construction standards in the same country. Rules and practice that impact legal status may change, and sometimes it is not possible to determine legal status by inspecting public records. Thus, even the most detailed infringement analysis of a claim is only an estimate, and you must inform the client of these potential problems and risks.

Although the client often wishes to have a definitive statement about non-infringement, you are not in a position to provide such certainty. Your conclusions after FTO analysis are based on a multistep analysis and a variety of factors can affect the accuracy of such conclusions. For example, the client could

change their invention during testing and product development, such that some or all of the analysis becomes irrelevant. In the hypothetical future litigation, the standards and rules for infringement analysis may have changed, or the court or tribunal may focus on different factors to interpret the claims, resulting in a slightly or drastically different conclusion. Where the FTO analysis includes claims in a pending patent application, the scope of those claims may change prior to grant and your analysis may not be accurate for the final granted claims.

Regarding the legal status of each claim, in some cases it is possible to report whether a claim is currently enforceable. In other cases, the current legal status of a claim cannot be determined. A patent may be involved in post-grant proceedings that could affect legal status, and the database being searched may not have been updated with information from these proceedings, or you may not have been able to find them, to determine whether legal status has changed. If the patentee made post-grant amendments, then the database being searched may or may not provide the updated claims that are currently in force. A pending application may issue as a patent after the FTO search, or it may have issued earlier but the database record was not updated by the time of the FTO search.

Finally, although FTO searches may be quite extensive, they are unlikely to be exhaustive. There may be patent documents that you did not discover during the FTO search for various reasons, such as the search terms did not find the patent document, or because the database was not up to date, or because a patent application that was filed within the previous 18 months has not been published yet. If a potentially relevant document was not in the search results, then no FTO analysis of the document was carried out.

**Risk management.** In view of the problems discussed above, every Final Report should include at least the following disclaimers:

- The report is based solely on the information provided to the reviewer, and any changes to the product by the client may alter the conclusions reached in the report.
- The report provides reasoned determinations, but patent litigation is inherently unpredictable. If litigation were to occur in the future, then a judge or jury or other decision-maker may reach conclusions that differ from those in the report, even in the face of overwhelming evidence.
- The report represents an attempt to apply current rules and standards that represent general principles of infringement analysis. Rules and standards in



each country may be different from the general principles applied in the FTO search and analysis reported. Rules and standards may change due to changes in the applicable laws and regulations, or due to judicial interpretation of these laws and regulations.

- The report provides the legal status of a patent as currently determined using general rules taught in the guide. In some cases, legal status of a patent or a claim could not be determined. Legal status of a patent, or a claim in a patent, can change in the future.
- If published patent applications were included, the report provides a determination regarding potential patent rights *if* the claim were to be granted in its present form. The analysis and determination may not apply to any claim that is further amended.
- If a patentee makes post-grant amendments, the analysis and determination in the report may not apply to the amended claim(s).
- The report is valid only insofar as the reviewed patent documents represent the results of the FTO search, but they do not necessarily represent the universe of patent rights in existence.
- The report represents the conclusions of informal FTO analysis and do not represent legal conclusions. The statements in the report do not constitute legal advice or business advice.
- No guarantees are provided with the report. Any determinations or conclusions provided in the report are made with an understanding of the uncertainties and risks associated with any FTO determination.

## 6. Going forward: Using the results in the Final Report

Keeping in mind all the limitations and uncertainties discussed above, the technical conclusions you present in the Final Report can help the client make informed decisions about how to proceed.

The client is responsible for considering all the information you provide, including information about potential risks, and then making informed decisions about how to proceed with their plans to use an invention.

### 6.1 If FTO search and analysis of patent documents in a country of interest did not result in classifying any patent as a “patent of interest – in force” in that country

*If* the conclusion of your FTO search and analysis for a country of interest is that *no* claim was classified in

Category 1 or Category 2, and *no* patent currently in force was classified as “patent of interest – in force” when your client plans to use the invention in that country (see Module IV, sections 6.1 and 6.2), then the client can evaluate options such as:

- Decide to **proceed with further development and/or use** of the invention in that country, assuming the risk of doing so. The client may seek guidance on further development in the WIPO publication *Using Inventions in the Public Domain: A Guide for Inventors and Entrepreneurs (2020)*.
- **Seek legal advice** from a legal professional (for example, an IP attorney) or qualified patent professional according to applicable laws of that country. Your infringement analysis is based on applying general principles of claim construction and comparison, and does not involve the application of country-specific legal standards. Your conclusion is presented in a technical report that does not reach a legal conclusion or provide legal advice. The client is responsible for taking additional steps such as seeking legal advice concerning this matter.
- Decide to **seek IP rights** in the invention in that country, if patent eligibility criteria can be satisfied.

### 6.2 If FTO search and analysis of patent documents in a country of interest resulted in classifying at least one patent as a “patent of interest – in force” in that country

*If* the conclusion of your FTO search and analysis for a country of interest is that *at least one* claim was classified in Category 1 or Category 2 and was found in an enforceable patent, such that at least one patent was classified as “patent of interest – in force” in that country, then the client should understand that there may be potential FTO issues for the invention in that country.

The client’s options may depend on whether the claims cover essential features of their invention that cannot be changed, or optional features that could be changed. The client can evaluate options such as:

- **License** the right to practice the invention defined by the claims in a patent identified as a “patent of interest – in force” from the patent owner.
- **Seek legal advice** from a legal professional (for example, an IP attorney) or qualified patent professional according to applicable laws of that country. For example, an IP attorney can consider whether the patent exhaustion or first sale doctrine, or a research exemption, would apply for a patent that covers a feature of the invention such as a chemical

ingredient or machine the client purchased. A legal professional might be able to advise the client about circumstances that would allow them to use the patented feature without further permission of the patent owner.

- **Design around** (modify) the invention to take it out of the scope of identified claims. You may be able to help the client identify potential alternatives that were disclosed in patents classified as “patent of interest – in force” but not claimed. This may trigger a need for additional FTO search and analysis of the modified invention.
- **Do not practice the invention in that country.** The client may limit use of the invention to selected jurisdictions where no enforceable patents with Category 1 or Category 2 claims were found.
- If the claims are found in patents that should expire soon, **postpone development or use** of the invention until any patents classified as “patent of interest – in force” have expired.
- Proceed with further development and/or use of the invention and **assume the risk** of doing so. The client may choose to rely on the fact that the patent owner has not attempted to enforce their patent rights so far.
- **Abandon** current plans for using invention.

## 7. Conclusion

This guide was written to teach you how to use the tools of FTO determination to explore the question of patent rights that may cover a client’s invention. Your goal is to use the tools of FTO determination to search and evaluate whether there are any enforceable patents that have the potential to impact a client’s planned use of an invention. Using these tools, you may be able to provide information that the client can use to make informed decisions about their plans for using an invention.

Although the title of this guide suggests that you will learn how to identify inventions in the public domain, in fact you have learned skills for using the tools of FTO determination to explore patent rights that may cover an invention. You have also learned to recognize the limitations of using these tools and what steps you can take to manage the associated risks.

That means you have learned skills that you can use for evaluating whether certain circumstances might be appropriate for identifying an invention as being in the public domain. For example, if you used the tools of FTO determination to explore patent rights around an invention and did not identify any “patents of interest –

in force” in a specific country during a specific time frame, and you can demonstrate that the invention has been disclosed to the public, then you can proceed to a consideration of whether the invention can be identified as being in the public domain in that country at the time the client plans to use the invention. If you identify an invention as being in the public domain, you do so with an understanding of the associated risks.

Any determination you make concerning patent rights that may cover a client’s invention, and any determination as to whether an invention appears to be in the public domain, is a technical determination and not a legal opinion. Any such determination is made without a guarantee and with full recognition of the potential risks. You will provide the client with information such as the search strategy you used, the search results you analyzed, the basis for any determinations you made, and the potential risks associated with the FTO process. The client is responsible for considering *all* the information you provide, including information about potential risks, and then making informed decisions about how to proceed with their plans to use an invention.

# Annexes

## Annex A.1

The following checklist of steps and considerations will help you identify the information you need to decide how to describe your client's invention. You may not need all the steps or information in every case you consider.

### Module II. Identifying technology information needs Checklist

- Interview client:** Gather information about the WHAT-WHERE-WHEN of the client's invention and their plans for using it.
  - Use the questions in Figure 2 (Module II), modified as needed.
  - Consult the main text for detailed guidance about the objective of the questions and the type of information to be gathered.
  - Use Figure 2 (Module II) as a worksheet to record answers and take notes.

---

- Part A. Questions: Technical information about the invention**
  - Section 1. Overview: goal, purpose, plans; problem to be solved
  - Section 2. Technical description of the invention
    - 2.A. Technical field(s) and type(s) of invention
    - 2.B. Technical details of the invention
      - Components and steps
      - Technical relationships between components and parts
      - End result
  - Section 3. Essential features
  - Section 4. Optional features
  - Section 5. Functional features (essential or optional)
  - Section 6. Significant limits; critical values and ranges
  - Section 7. Equivalents and alternatives; use of commercial products or processes
  - Section 8. Documents: additional information; non-text features
  - Section 9. Background information
  - Section 10. Differences and distinguishing features.

---

- Part B. Questions: Business information about the invention**
  - Section 11. Where and when the client plans to use the invention
    - Countries to be searched
    - Time frames to be searched
    - Subject matter specific to countries or time frames.

---

- Follow-on analysis and Summary Report**
  - Review interview notes and any documents provided by the client.
    - Decide whether additional research is needed.
  - Organize and summarize information; prepare answers for the Summary Report.
  - Complete the Summary Report using the template at Annex A.2.

---

- Summary Report Part A. Technical information**
  - **Technical description of the invention**
    - Start with the invention description for Section 2.B of the Summary Report: “a summary of the invention that describes how the invention is carried out from beginning to end.”
    - Complete Section 2.B: components, steps, functions; interactions; end result(s).
    - Complete Sections 1 and 2.A.
  - **Invention features, details, prior art**
    - Complete Sections 3–8 to identify different types of features and technical details of the invention.
    - Complete Sections 9–10 with the client's understanding of the invention and prior art.

**Summary Report Part B. Business information**

- Complete Section 11: Client’s plans for using the invention.
    - List countries for the FTO search.
    - For each country, list the projected dates of use (time frame).
    - Identify whether the client plans different activities in different countries; if so, identify what the client plans to do in each country.
    - Optional: Comment on different countries as potential target markets.
- 

**Summary Report Part C. Additional analysis**

- **Initial set of keywords and phrases**
    - Review interview notes and answers for Part A of the Summary Report and collect an initial set of keywords and phrases relating to the invention.
  - **Optional: Draft patent-style claims to describe the invention**
    - At least one broad independent claim that describes the invention in terms of all of its essential features.
    - Optional: Narrower dependent claims that recite optional features as additional claim limitations; a “picture claim” that recites the components and steps exactly as the client practices the invention.
  - **Optional: Additional comments or materials**
-

## Annex A.2

The Summary Report can be prepared using the template below. The left column refers to interview questions and their objectives, as shown in Figure 2 (Module II). The right column provides spaces to enter information as indicated, to generate the report.

### Module II: Identifying technology information needs Template for Summary Report

Interview questions	Information from interview notes, document review and follow-on analysis.
<b>A. Technical information: Invention overview, details, background</b>	
1. Overview: goal, purpose, plans  Problem to be solved	<ul style="list-style-type: none"> <li>– List the problem to be solved.</li> <li>– List the goal or purpose of the invention (if this is different from the problem to be solved).</li> <li>– Define the technical problem to be solved.</li> </ul>
2. Technical description of invention  A. Technical field(s) and type(s) of invention  B. Technical details of invention:  Components and steps; technical relationships; end result	<p>A. List the technical field(s) of the invention.</p> <ul style="list-style-type: none"> <li>– List type(s) of invention.</li> </ul> <p>B. Provide a summary of the invention that describes how the invention is carried out from beginning to end.</p> <ul style="list-style-type: none"> <li>– List components of the invention.</li> <li>– List steps of the invention and the components used in the steps.</li> <li>– Identify features of the invention by describing the invention from beginning to end, in terms of technical effects of the interactions of components and steps.</li> <li>– Describe the end result of the invention in terms of technical features that solve the technical problem.</li> <li>– Identify components that may be non-text features: <ul style="list-style-type: none"> <li>· Technical/mechanical drawings, flow charts, diagrams</li> <li>· Chemical compounds (may trigger a chemical structure search)</li> <li>· Protein or nucleotide sequences (may trigger a sequence search).</li> </ul> </li> </ul>
3. Essential features	<ul style="list-style-type: none"> <li>– List essential features of the invention. These features will be the most important source of the keywords and phrases that you will use for keyword searching and patent classification searching.</li> <li>– List keywords and phrases from essential features.</li> </ul>
4. Optional features	<ul style="list-style-type: none"> <li>– List optional features. These features may be used to refine searches.</li> </ul>
5. Functional features	<ul style="list-style-type: none"> <li>– List functional features. Structure–function analysis will be needed to identify components and/or steps capable of performing the function. Make sure any patent-style claims recite functional features.</li> </ul>
6. Significant limits  Critical values and ranges	<ul style="list-style-type: none"> <li>– List any limits on components, steps or features the client has identified. <ul style="list-style-type: none"> <li>· For each limit, identify the component, step or feature that is limited.</li> </ul> </li> <li>– Identify any negative limits and the associated component, step or feature. Flag negative limits that can be used to exclude subject matter from searches.</li> <li>– List any critical values or ranges and the associated component, step or feature.</li> </ul>

7. Equivalents and alternatives  Use of commercial products or processes	<ul style="list-style-type: none"> <li>– List any equivalents the client has identified and what component, step or feature they can be substituted for. Include synonyms.</li> <li>– List any alternatives the client has identified and what component, step or feature they are an alternative for. Decide whether any alternatives are so different from the original description of the invention that they represent a different invention that may need a separate search.</li> <li>– List commercial products or processes used by the client, with their generic name(s); add generic name(s) to the list of keywords.</li> </ul>
8. Additional information in documents; non-text features	<ul style="list-style-type: none"> <li>– List any additional features, limits or other useful information found in additional documents.</li> <li>– List any non-text features.</li> <li>– If the invention includes any non-text features such as chemical compounds or nucleotide/protein sequences, extract them for searching.</li> </ul>
9. Background information	<ul style="list-style-type: none"> <li>– List any parties of interest and third-party IP rights identified by the client.</li> </ul>
10. Differences and distinguishing features	<ul style="list-style-type: none"> <li>– List any differences identified by the client and indicate any differences considered to be very important.</li> </ul>
<b>B. Business information: Where and when the client plans to use the invention</b>	
11. Countries and time frames to be searched  Subject matter specific to countries or time frames	<ul style="list-style-type: none"> <li>– List countries to include in the FTO search (and language translations that may be needed).</li> <li>– List projected dates of use in each country.</li> <li>– Identify what the client plans to do in each country.</li> </ul>
<b>C. Additional analysis</b>	
Initial set of keywords and phrases	<ul style="list-style-type: none"> <li>– List keywords and phrases based on the components, steps and essential features you have identified.</li> </ul>
Patent-style claims	<ul style="list-style-type: none"> <li>– List any patent-style claims you have drafted to describe the invention.</li> </ul>
Additional notes, comments, materials	<p>For example, you can include figures, diagrams, flow charts and similar that you have developed to convey information about the client's invention and their plans to use it.</p>

## Annex B.1

The following checklist of steps and considerations will help you carry out an FTO search. You may not need all the steps or information in every case you consider.

### Module III: FTO search Checklist

- Develop inputs for keyword searching:** Deconstruction and keyword expansion

---

- Deconstruct the invention:** Formulate a broad generic description of how the invention solves a problem.
  - Identify essential features of the invention (see Part A.3 and any patent-style claims in Part C of the Summary Report).
  - Deconstruct components and steps separately; deconstruct composite components or steps; deconstruct functional features.

---

- Develop expanded list of keywords and phrases**
  - Collect keywords and phrases:
    - Use the results of deconstruction to write a comprehensive description of features.
    - Review the initial set of keywords and patent-style claims (Part C in Summary Report) for additional keywords.
  - **Expand keywords:** Find synonyms and equivalents; carry out structural and functional expansion; use WIPO Pearl to find terms already used in patent documents.
  - **Recommended:** Test keywords for relevance.

---

- Find potential patent classification symbols** that may be associated with the invention

---

- Map keywords and phrases to classification symbols, specifically IPC symbols.
  - Use tools to find symbols that may apply: IPCCAT, STATS, term search.
  - Find classification symbols associated with known patent documents, such as patents the client may have identified, or patents found in keyword searches.
  - Test and rank IPC symbols for their ability to find documents relevant to features.

---

- Select database(s) to search**

---

- **Geographical coverage** for each country of interest: Complete and up to date?
  - **Temporal coverage** for each country of interest: Does it go back far enough?
  - **Search functions:** Ability to search abstract, claims, full text, title, other information such as patent owner, legal status. Ability to search published applications. Ability to view images. Ability to search non-text features (if any).
  - **Language support:** Ability to search in desired language(s); translation tools.
  - Ability to retrieve technically useful patent records for analysis and reports.

---

- Decide whether searching multiple databases is necessary to achieve the desired coverage and functions.

---



---

 **FTO search: Hybrid strategy using keywords and patent classification symbols**

---

- 
- **Strategy: Search claims and abstract first** (title optional); store *all* searches and search results.
  - **Initial broad search:** Use a search string with a comprehensive set of keywords (and phrases) combined with a comprehensive IPC symbol set.
    - Review, sort and rank the initial search results.
  - Modify and refine the search as necessary (if the initial search returned too many results, or results that are clearly too broad or not relevant).
    - Initial modification: Feature-specific searches; search strings with keywords and IPC symbol associated with a specific feature; review results
    - Options: Query reduction or query expansion; expand search scope
    - Use tools: WIPO Pearl to test keywords; WIPO CLIR to search non-English documents; translation tools; IPCCAT or STATS to refine IPC symbols.
- 

- 
- Search non-text features (if any): Use specialist databases if necessary to search chemical structures, sequences, etc.
- 

- 
- Continue to refine and review your FTO search and *decide when to stop*.
- 

 **Prepare Search Report**

---

- 
- Select the final search results to include in your report.
  - Optional: Sort and/or rank the search results, remove duplicates.
  - Format the search results, preferably as a table that identifies the patent document and indicates how it matches the search inputs.
- 

- 
- Your Search Report will include:
- Search overview:
    - Brief description of the invention and features searched
    - List of keywords and phrases, IPC symbols, databases searched, languages and tools used, such as translation tools; any client-specific criteria.
  - Search strategy:
    - Show selected search strings and the number of patent documents returned
    - Mention any strategic decisions including modifications to the search, your decision to stop searching, criteria for ranking results.
  - Search results:
    - Options: A single master list (table) or multiple lists
    - Options: Arrange by country or predicted expiration date or an essential feature of the invention, assigned rank, client concerns.
  - Conclusions: Keep these minimal.
-

## Annex C.1

FTO analysis includes two separate analyses: infringement analysis and determination of legal status. The following checklist of steps and considerations will help you analyze potentially relevant patent documents you found during the FTO search. You may not need all the steps or information in every case you consider.

### Module IV. FTO analysis: Reading claims and legal status information Checklist

**Organization of FTO analysis**

- Decide how you will organize the search results (e.g., by country, feature or ranking) before beginning the FTO analysis or after.
- Decide whether to do the infringement analysis first, or the legal status determination first.

**Infringement analysis:** Determine the potential scope of a claim, and whether the claim could be found to cover the client's invention.

- Start with the independent claims of each patent.
- Optional: Do a quick comparison of a claim with the client's invention. If the claim language requires a feature that the client's invention clearly does not have, detailed analysis may not be necessary. Take notes on the differences.

- Claim construction:** Interpret (construe) the meaning and scope of a claim (see Annex C.2.a).
- Use the claim chart worksheet at Annex C.2.b to organize your analysis.
  - Break the claim down and paste the preamble, transition and each claim limitation (element) into a separate row of the claim chart.
  - Construe (interpret) the scope of each claim part and limitation:
    - Start with the claim language (plain meaning) – what is required?
    - Consult additional sources of information (specification, prosecution history, etc.).
  - Enter notes on claim construction into the claim chart for each part and limitation.

- Comparison step:** Compare the construed claim with the client's invention.
- For each claim part or limitation, look at the client's invention and determine whether it satisfies the requirements of that part or limitation.
  - For each claim part or limitation, enter information about the client's invention in the same row, in the column titled "Corresponding structure in client's invention."
    - If the client's invention has no corresponding structure or function, then leave the cell blank or make notes about the differences.
    - The client's invention may have additional features not found in the claim.
  - For each claim part or limitation being compared, enter your conclusion in the column titled "Limitation satisfied?" with explanatory notes if necessary.

**Reach a conclusion for infringement analysis of the claim:**

- Based on comparison of the construed claim as a whole with the client's invention as a whole, reach a conclusion for that claim:
  - **Could be interpreted to cover the client's invention** (Category 1 claim) or **may be interpreted to cover the client's invention** (Category 2 claim)
  - **Does not appear to cover the client's invention** (Category 3 claim)
  - **Cannot determine** (Category 4 claim): The scope of a claim limitation was not clear, or something in the client's invention was unclear or unknown.
- Repeat for each independent claim in the patent (or application).
  - If an independent claim is classified as a Category 1 or 2 claim, then analyze dependent claims.

- 
- Determine legal status:** Is a patent enforceable in the place where and the time when the invention will be used?
- 
- 
- For each granted patent, determine the legal status:
    - **In force** (“alive”). Calculate the expected patent term.
    - **Expired/unenforceable** (“dead”). If the patent became unenforceable before the full patent term ended, what happened?
    - **Ambiguous/unsettled** legal status.
  - If you analyzed published applications, determine if the application is still pending. If yes, determine the potential patent term for any potential future patent rights.
- 
- Final determinations based on FTO analysis:** Classify each patent based on infringement analysis *and* legal status determination.
- 
- 
- **Patent of interest:** At least one Category 1 or 2 claim. Any “patent of interest – in force” should be brought to the client’s attention.
  - **Not likely to be of interest:** All claims are Category 3.
  - **No analysis of claims was carried out** because they were in an unenforceable patent.
  - **No determination can be made:** You could not reach a conclusion during infringement analysis (all claims Category 4) and/or could not make a determination of legal status.
- 
- Prepare Final Report:** Use the template at Annex C.3.
- 
- 
- **The invention:** Technical description of the invention and the client’s plans for use.
  - **FTO search:** Summary of the FTO search; no analysis.
  - **FTO analysis:** Report findings using technical language.
    - Identify all analyzed documents, with final determination and classification.
    - Discuss specific patent documents you want to bring to the client’s attention.
- 
- Conclusions and disclaimers:**
- Summarize the most important results and details.
  - Discuss the limitations and risks of FTO determination, and especially the risks of FTO analysis.
-

## Annex C.2.a

### Module IV. FTO analysis: Reading claims and legal status information Claim chart template with comments and instructions

Patent no. Claim no.

Claim limitation	Claim construction	Corresponding structure in client's invention	Does this limitation appear to be satisfied?
[Paste in the <b>claim</b> , word for word from the original. Break up the claim into preamble, transition and limitations. Each limitation is given a separate row. Limitations are typically, although not always, separated by semicolons.]	[This column allows you to enter notes and comments. These notes should help you understand the scope of the preamble, the transition and each claim limitation.]	[Anything from the client's invention that might fall within the scope of what is recited in the corresponding part of the claim, in particular each claim limitation, is placed in this column. Include explanations if necessary.]	[Try to draw a conclusion (with explanatory notes if necessary) as to whether, or to what extent, the claim limitation is satisfied. Select from "yes" or "no" or "probably yes" or "probably no" or "definitely no" or "cannot determine."]
[Paste <b>preamble</b> here.]	[Interpret the preamble: What type of invention is it? What is the general subject matter of the claim?]	[Compare the preamble with the client's invention. Discuss whether the client's invention includes the same type of invention and general subject matter.]	[Decide if the client's invention might fall within the same invention type and subject matter.]
[Paste <b>transition</b> or transitional phrase here.]	[Interpret transition phrases such as: "comprising" or "consisting of" or "consisting essentially of" or "characterized by."]	[Decide whether the transition is significant.]	[Decide if the transition has an effect on the final determination.]

[Paste <b>first limitation</b> here.]	[Discuss the scope of the limitation. This section can include comments about how this limitation is described in the specification.]	[Compare the first limitation with the client's invention. Discuss whether there is a corresponding element or structure in the client's invention. This may be a discussion of what appears to be similar <i>or</i> what appears to be different <i>or</i> what is ambiguous.]	[Decide whether the first limitation is satisfied by a corresponding element or structure in the client's invention. If necessary, include remarks explaining your conclusion. Options for the conclusion include: "yes" or "no" or "probably yes" or "probably no" or "cannot determine."]
[Continue to paste one claim limitation in each row.]	[Discuss the scope of each limitation.]	[Compare each limitation with the client's invention.]	[Decide whether each limitation is satisfied by a corresponding element or structure in the client's invention.]
...	...	...	...

**Additional notes:****Assign a claim category based on comparison of the claim as a whole with the invention as a whole** (see Module IV, section 6.1).

1. Could be interpreted to cover the client's invention.
2. May be interpreted to cover the client's invention.
3. Does not appear to cover the client's invention.
4. No determination can be made.

**Conclusion:****Claim category:****Additional comments:**

## Annex C.2.b

The worksheet below provides a template to generate a claim chart for a single claim. Use a separate worksheet for each claim and customize it by adding enough rows to provide a separate row for each claim limitation or part.

### Module IV. FTO analysis: Reading claims and legal status information Claim chart worksheet

Patent no. Claim no.

Claim limitation	Claim construction	Corresponding structure in client's invention	Does this limitation appear to be satisfied?

**Additional notes:**

**Assign a claim category based on comparison of the claim as a whole with the invention as a whole** (see Module IV, section 6.1).

1. Could be interpreted to cover the client's invention.
2. May be interpreted to cover the client's invention.
3. Does not appear to cover the client's invention.
4. No determination can be made.

**Conclusion:**  
**Claim category:**

**Additional comments:**

## Annex C.3

This template is provided to demonstrate how the Final Report can be organized and presented. The remarks in *italics* are merely observations and suggestions. It is important to follow instructions in the checklist and consult the discussion of the Final Report in Module IV for more detailed guidance.

### Module IV. FTO analysis: Reading claims and legal status information

#### Template for Final Report

*Mark every page of this document as confidential*

#### Title of project

##### Introduction and identification:

*Identify the client, the TISC and the TISC staff involved in the search.*

*These remarks can include a summary of interactions between the TISC and the client: for example, initial contact, interview, period of search, time frames.*

#### The invention

##### Summary of invention:

*Provide a brief summary of the client's invention based on the Summary Report from Module II, and any additional understanding of the invention you have gained during the remainder of the project.*

*This summary allows the client to see how you understood the invention (and to make corrections to this understanding, if necessary).*

**Description of the client's invention:** *Provide more detail about the invention, based on technical information you gathered in Question 2, and any additional relevant information.*

**Patent-style claims:** *If you drafted patent-style claims, list those here.*

**Essential features:** *Briefly list components, steps (processes), functional features, critical values (limits), critical ranges and other items that you identified as essential features of the invention.*

##### Other technical information used for the FTO

**search:** *List optional features, alternatives, non-text features such as flow charts, chemical structures, protein or nucleotide sequences and any subject matter that was specifically excluded.*

**Client's plans for using the invention:** *Add the business information from Part B of the Summary Report.*

##### Country or countries of planned use:

##### Planned activity/activities in each country:

##### Time frame(s) for each country:

#### FTO search

**Summary of the FTO search:** *In this part of the report, a brief summary of the FTO search should include the following information (if relevant) and any additional information and comments that would clarify details of the FTO search or improve understanding of the results.*

##### Databases searched:

**Countries and patent offices searched:** *EPO or WIPO/PCT is a "patent office."*

##### Language(s) used for searching:

**Time limits:** *If the search was limited to a specific time frame, then identify time limits.*

**Types of patent documents searched:** *Granted patents only? Published patent applications?*

**Subject matter searched:** *Claims, title, abstract, etc.*

##### Search terms and patent classification symbols

**that were used for searching:** *A summary of the search terms can be displayed in a table as shown below. You may want to include the number of results for each feature or input. You can include remarks about tools or strategies you used to find keywords or patent classification symbols, such as WIPO Pearl, IPCCAT, STATS, CLIR or tools provided by commercial databases.*

Invention feature	Keywords, search terms	IPC

**Optional: Provide details of search strings and refinements of the search:** *If applicable, show search*

*strings and discuss any refinements to the search that produced better results.*

**Other types of searches, if any:** *Mention other types of searches if they were performed; for example, searches for non-text features such as chemical structures or sequence information, or searches for specific inventors or companies.*

#### **Summary of FTO search results:**

*Provide a brief summary of the search results. For example:*

*How many documents were found? Additional information can include: the number of documents found at various stages of the search and decisions you made about how to refine the search.*

*How many potentially relevant patent documents (out of the total search results) were identified as “potentially relevant patent documents” and selected for further analysis? What were the criteria for identifying a search result as a potentially relevant patent document and selecting it for further analysis?*

*Did you use specific criteria to identify some of the search results as “not potentially relevant” and exclude them from further analysis?*

*Include any additional remarks you consider to be useful.*

## **FTO analysis**

### **Introduction and overview**

*Information should be organized in a way that will be useful to the client. You may want to include remarks about how and why you organized the information this way.*

*Include remarks about whether you did any cleaning up of the search results. One type of cleanup would be determining legal status first to find unenforceable patents (expired, lapsed, abandoned, withdrawn, invalidated, disclaimed, etc.). Another type of cleanup would be doing a quick comparison of patent claims with the client’s invention to see if the claims required features (elements) that are clearly not found in the client’s invention. Did you decide that you did not need to carry out a complete infringement analysis on these patents?*

*The FTO analysis section should list all of the patents that you identified as potentially relevant and selected*

*for further analysis of any kind. If you analyzed other types of patent documents, such as pending applications, utility models (petty patents) or patents from non-target countries, then they should also be listed.*

*One option is to provide a master list of all the patent documents that you analyzed, arranged in table format with one patent document per row. The entry for each patent should include minimum bibliographic data such as number, title, date of grant, country of grant, priority date and predicted expiration date, and could include inventors, owners (applicants, assignees) or other information. (If you analyzed patent applications or other patent documents that were not granted patents, it may be useful to show this in a separate table.) This provides a useful summary of the FTO analysis step.*

*If you made a legal status determination, then list it in the table, with wording such as “in force” or “unenforceable” or “cannot determine” or “did not determine.” Include remarks on the analysis you carried out, for instance whether you carried out an infringement analysis or legal status determination, and whether you carried out both types of analysis or just one.*

*The table should include a column to enter a summary of the final determination, listing patent classification and remarks. Patent classification options are:*

- “Patent of interest” (Category 1 or 2 claims) and whether it is “in force” or “expired/unenforceable”
- “Not likely to be of interest” (Category 3 claims) and whether it is “in force” or “expired/unenforceable”
- “No analysis of claims because patent is expired/unenforceable”
- “No determination can be made” (claim scope was unclear (Category 4 claims) or legal status was unclear).

**Discussion of individual patent documents:** *In this part of the report, discuss the patents (and applications) that you want to bring to the client’s attention. You do not have to discuss every patent (or application) you analyzed.*

**Patent information:** *For each patent you want to discuss, identify the patent by number and title, provide additional bibliographic information such as country of grant, inventor(s), owner(s), priority claims, all assigned IPCs, predicted expiration date and legal status, along with a link to an electronic copy (if feasible). If you already prepared a master table, less information is necessary here. Optional information could include patent family information (if any), a list of the IPCs that matched search terms and excerpts of relevant text that show where keyword matching occurred.*



**Claims that were analyzed:** Add claim text if feasible and conclude with remarks on the results of the infringement analysis for each claim that you analyzed and how you classified it.

**Claim charts and details of analysis:** For each patent that you discuss in detail, decide whether you want to include claim charts and discuss the infringement analysis and legal status determination for each claim. You can decide whether to include a claim chart for each claim you discuss, or only for certain claims of greater interest.

If applicable, list sources of information that you used to construe claims or determine legal status.

**Remarks and additional analysis (optional):** You can include general observations, in view of the complete FTO analysis. For example, you can discuss whether you found many potentially relevant patents, or just a few or none, and what that may indicate about inventive activity in the relevant technological area. You can discuss obstacles you encountered during the FTO search process. You can discuss similarities and differences you observed between elements of your client's invention and the inventions in various analyzed patents.

## Conclusions

Remember, this may be the only section the client will read in detail. Include a summary of the most important results and the most significant details of the analysis, and emphasize the information that you want the client to take away from this project.

**Report your findings using technical language.** Do not use legal language. Do not characterize any conclusion as a legal opinion.

You may choose to draw the client's attention to certain patents (or pending applications) that you think are particularly relevant, especially patents classified as "patent of interest – in force" after your final determination. You can discuss your findings based on your application of the tools of FTO analysis as taught in the guide, but do not use legal language or draw legal conclusions when you discuss any patent or application.

Identify issues that remain unsettled, and circumstances where you could not reach a firm conclusion or make a final determination.

If you choose to discuss any circumstances where the record suggests the invention may be in the public domain in a specific country during a defined time frame, explain the evidence and your reasoning process. Describe any potential sources of error that may apply.

**Limitations and risks associated with this process:** This section is required.

**General remarks:** Include general remarks about the limitations, potential errors and risks associated with the FTO determination process. Module I of the guide provides a summary, and Module V provides a detailed discussion, including possible disclaimers to include in the report.

**Include remarks that are specific to this project:** For example, you may have found it difficult to search the published patent literature in a specific country, or in a specific database. You may have learned that patents from one country of interest are not regularly posted to a database, such that database coverage for that country is incomplete. You may have encountered difficulties with language, or with translation tools. It may have been difficult or impossible to gain access to information that would allow you to determine the legal status of certain patents (or pending applications).

If you concluded that the record suggests the invention may be in the public domain in a specific country during a defined time frame, then discuss the uncertainties and potential for error associated with identifying inventions in the public domain. Here, the discussion should include general principles as taught in the guide, and specific circumstances related to this project.

Do not provide advice to the client in your report. The report has been prepared to communicate information that the client can consider as they make decisions to proceed. The client is responsible for making their own decisions and assuming the risks associated with those decisions.

Include a final reminder that your report is merely a report of technical analysis and does not provide legal advice. State that the report, and any search and analysis performed for this project, does not substitute for the advice of a legal professional.

## Annex D

### WIPO resources and tools

#### Studies

Conley, J.G., P.M. Bican and N. Wilkof (September 16, 2013). *Study on Patents and the Public Domain (II)*. (CDIP/12/INF/2 REV). WIPO.

Phillips, J., M. Sibanda, H. El Saghir, E. Rengifo García, O.P. Orlyuk and C. Gabriel (February 28, 2012). *Study on Patents and the Public Domain*. (CDIP/8/INF/3 REV. 2). WIPO.

#### Guides

WIPO Patent Drafting Manual (2007):  
[www.wipo.int/publications/en/details.jsp?id=297](http://www.wipo.int/publications/en/details.jsp?id=297)

WIPO Guide to Using Patent Information (2015):  
[www.wipo.int/publications/en/details.jsp?id=180&plang=EN](http://www.wipo.int/publications/en/details.jsp?id=180&plang=EN)

PATENTSCOPE: The User's Guide (2020):  
[https://patentscope.wipo.int/search/help/en/users\\_guide.pdf](https://patentscope.wipo.int/search/help/en/users_guide.pdf)

Using Inventions in the Public Domain: A Guide for Inventors and Entrepreneurs (2020). WIPO.

#### Tools

International Patent Classification (IPC):  
[www.wipo.int/classifications/ipc](http://www.wipo.int/classifications/ipc)

PATENTSCOPE:  
[www.wipo.int/patentscope](http://www.wipo.int/patentscope)

PATENTSCOPE Tutorials:  
<https://patentscope.wipo.int/search/en/tutorial.jsf>

PATENTSCOPE Webinars:  
[www.wipo.int/patentscope/en/webinar](http://www.wipo.int/patentscope/en/webinar)

WIPO CLIR:  
<https://patentscope.wipo.int/search/en/clir/clir.jsf?new=true>

WIPO Patent Register Portal:  
[www.wipo.int/patent\\_register\\_portal](http://www.wipo.int/patent_register_portal)

WIPO Pearl:  
[www.wipo.int/reference/en/wipopearl](http://www.wipo.int/reference/en/wipopearl)

WIPO Translate:  
[www.wipo.int/patentscope/en/wipo-translate](http://www.wipo.int/patentscope/en/wipo-translate)

#### Other useful resources

WIPO Technology and Innovation Support Centers (TISCs): [www.wipo.int/tisc](http://www.wipo.int/tisc)

## Endnotes

- 1 See 35 U.S.C. §154(a)(1) and (2).
- 2 Phillips, J., M. Sibanda, H. El Saghir, E. Rengifo García, O.P. Orlyuk and C. Gabriel (February 28, 2012). *Study on Patents and the Public Domain*. (CDIP/8/INF/3 REV. 2). WIPO.
- 3 35 U.S.C. §112(b); see also, EPC Article 84.
- 4 MPEP § 2133, citing *Manville SalesCorp. v. Paramount Sys. Inc.*, 917 F.2d 544, 549 (Fed. Cir. 1990), discussing pre-AIA 35 U.S.C. §102(b), also applicable to the public use and on-sale bars of current (AIA) 35 U.S.C. §102(a)(1).
- 5 MPEP §2145, regarding non-obviousness issues, citing *In re Wiseman*, 596 F.2d 1019, 201 USPQ 658 (CCPA 1979); *In re Baxter Travenol Labs.*, 952 F.2d 388, 21 USPQ2d 1281 (Fed. Cir. 1991).
- 6 MPEP §1412.02, in the United States of America, a patent holder may seek reissue of an issued patent under 35 USC §251, and the “recapture rule” is a judicially created doctrine.
- 7 See Phillips, J., M. Sibanda, H. El Saghir, E. Rengifo García, O.P. Orlyuk and C. Gabriel (February 28, 2012). *Study on Patents and the Public Domain*. (CDIP/8/INF/3 REV. 2). WIPO.
- 8 Alberts D. *et al.* (2017) Introduction to Patent Searching. In Lupu M., Mayer K., Kando N., Trippe A. (eds) *Current Challenges in Patent Information Retrieval*. The Information Retrieval Series, vol 37. Berlin, Heidelberg: Springer.

World Intellectual Property Organization  
34, chemin des Colombettes  
P.O. Box 18  
CH-1211 Geneva 20  
Switzerland

Tel: +41 22 338 91 11  
Fax: +41 22 733 54 28

For contact details of WIPO's  
External Offices visit:  
[www.wipo.int/about-wipo/en/offices](http://www.wipo.int/about-wipo/en/offices)

FIG. 6

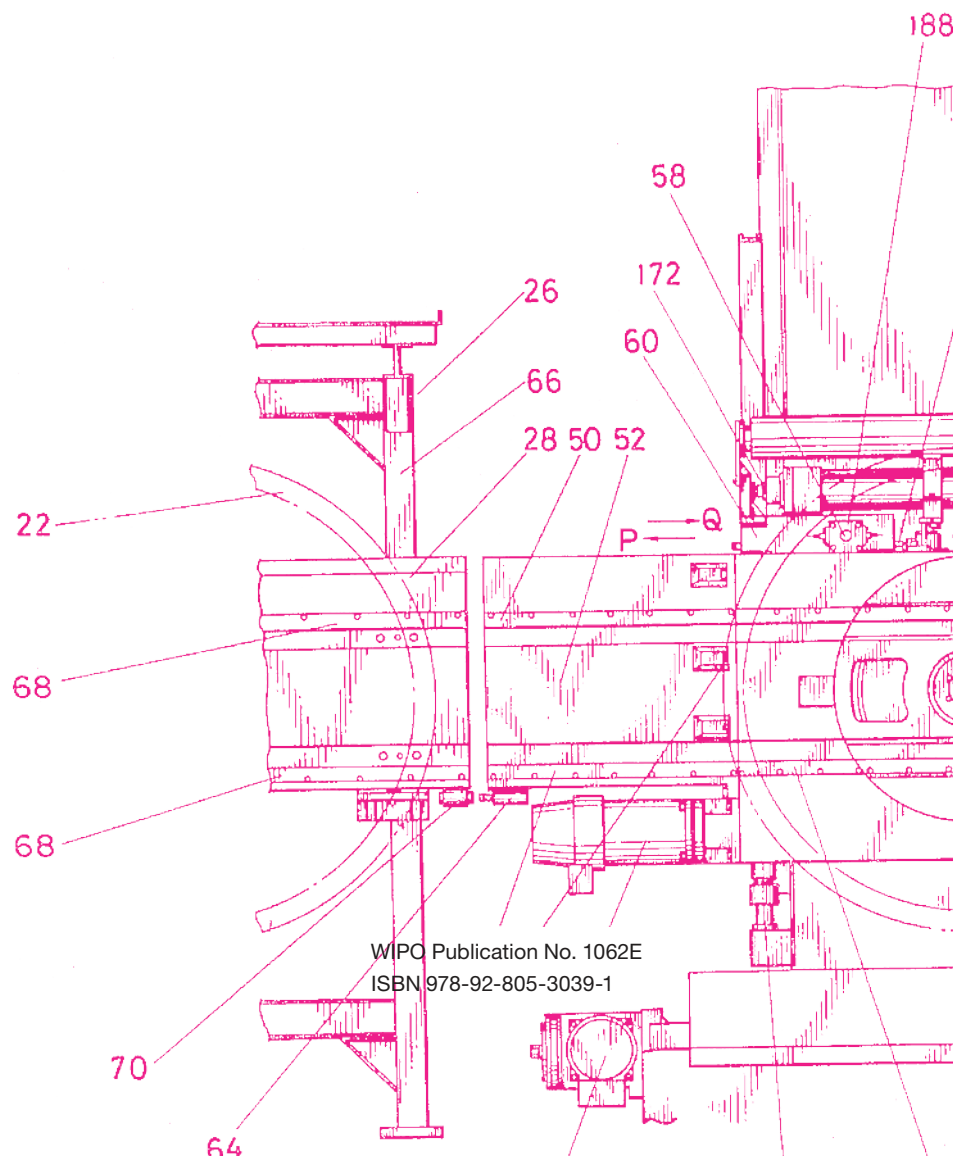

WIPO Publication No. 1062E  
ISBN 978-92-805-3039-1